

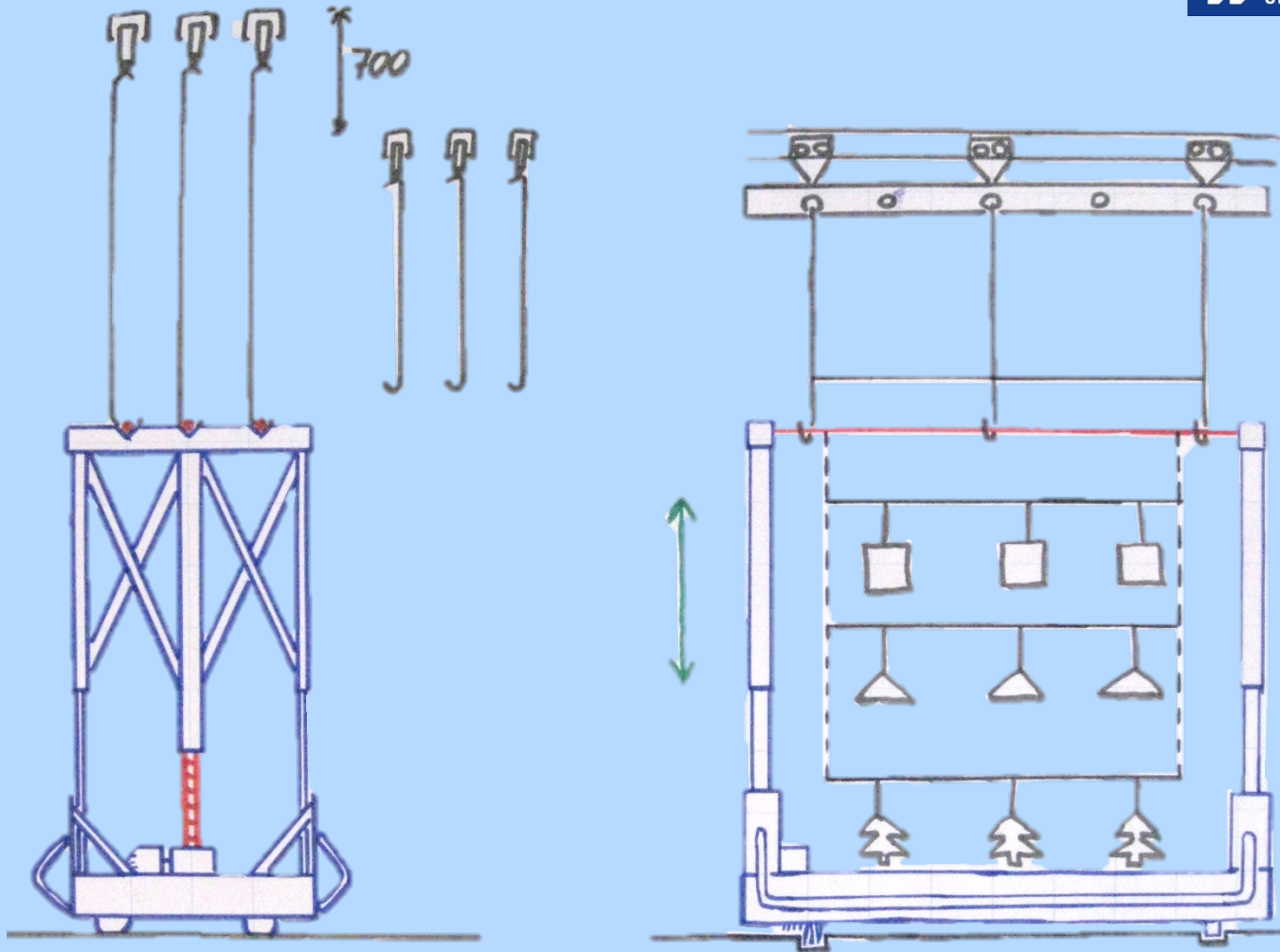

„Strong Ilse“

Gesamtsystem



Traversen/Schienen

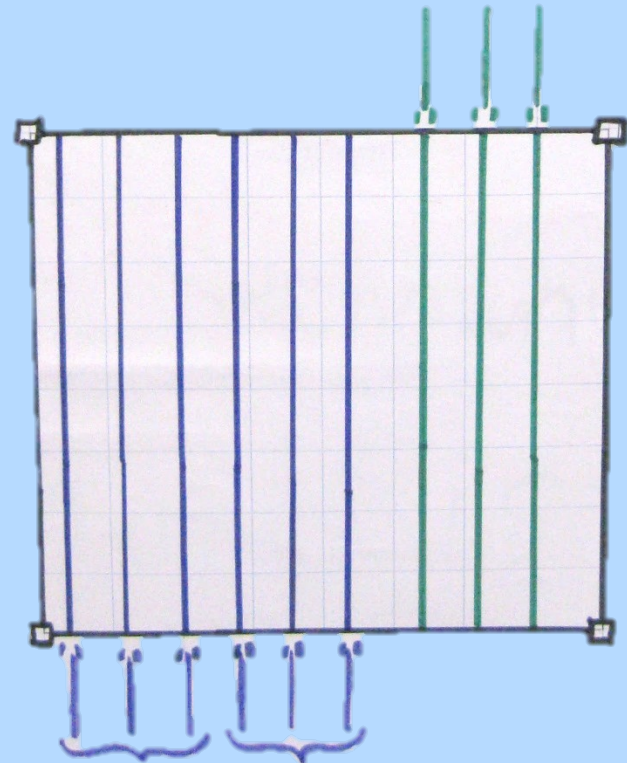
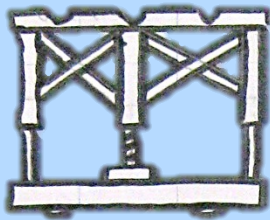
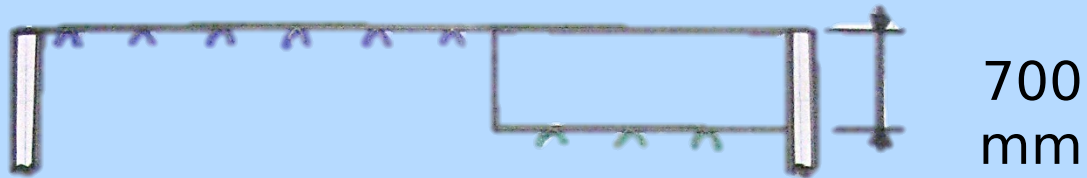

Griff & Steuerelement

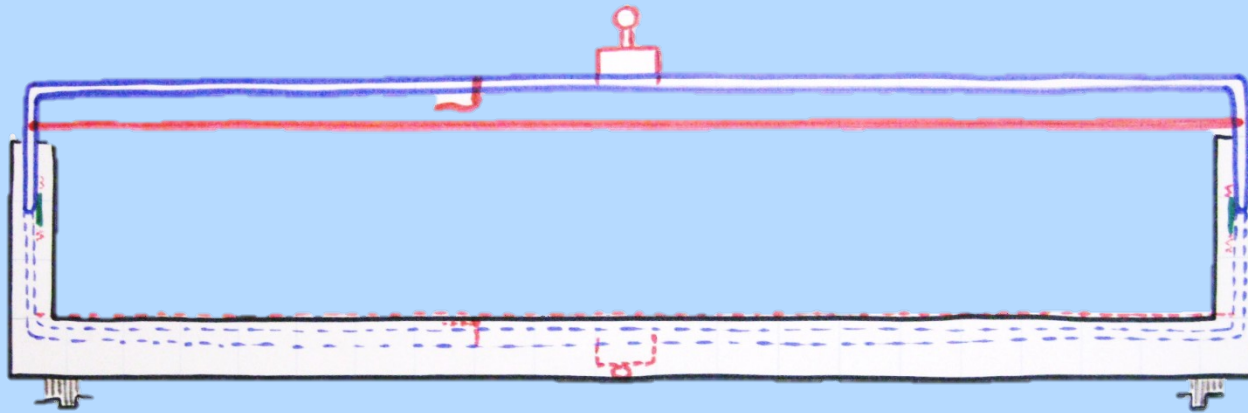

Vorderansicht
t



Seitenansicht
ht

„Strong Ilse“

Bürstensystem

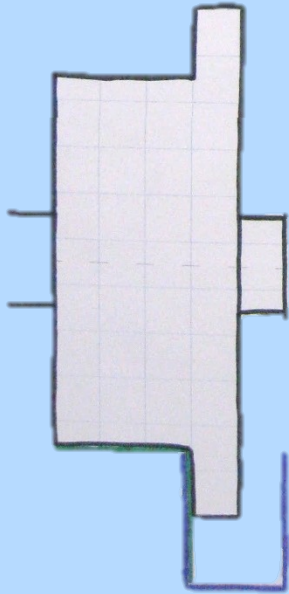

Seitenansicht
t

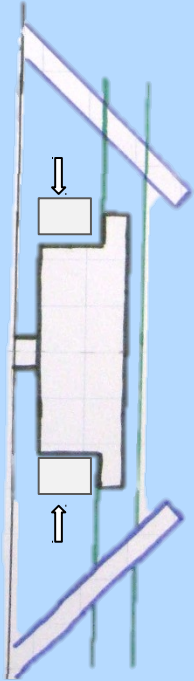

Draufsicht
t



Bürste

„Strong Ilse“

Hubsystem

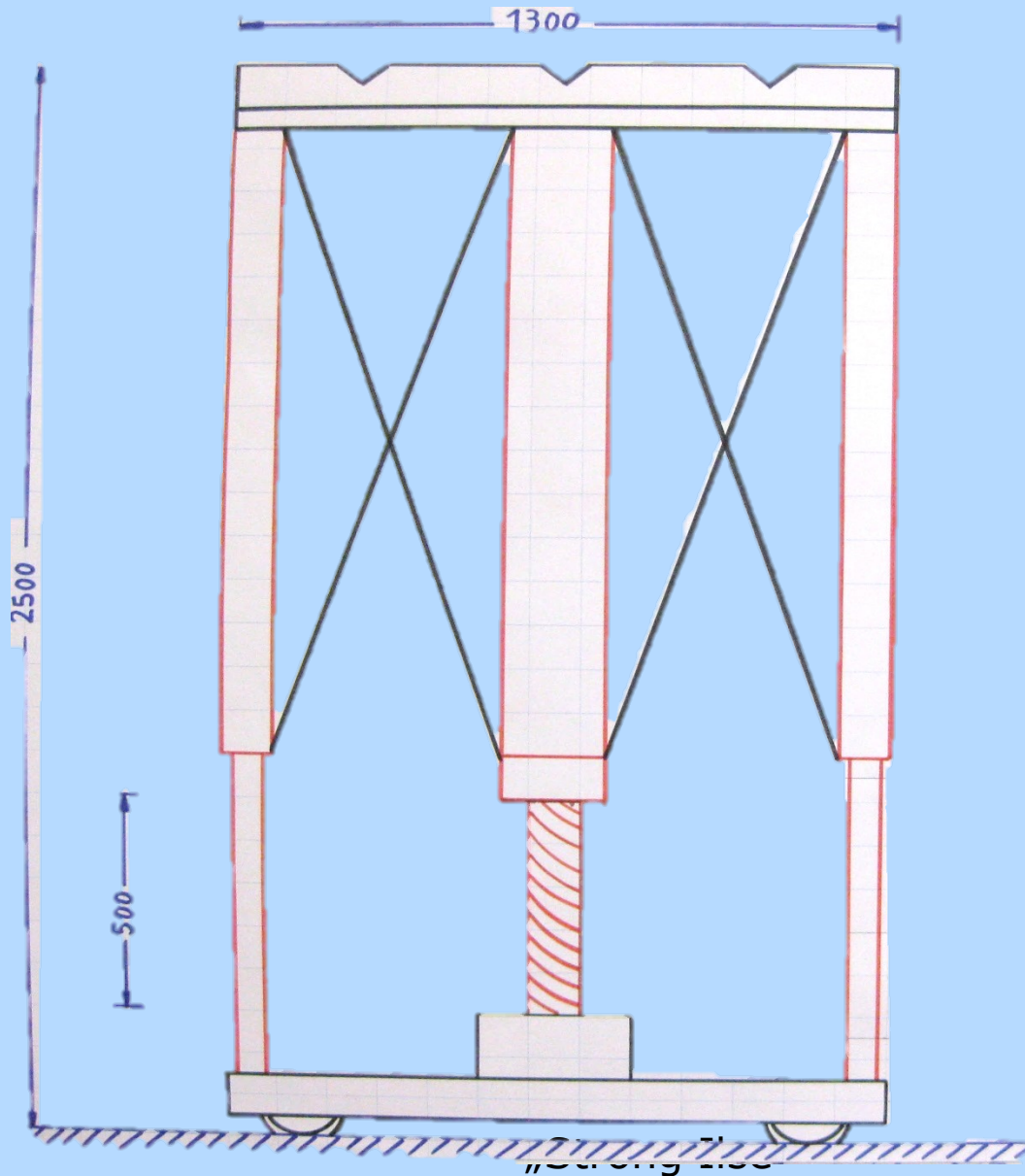

Materialkosten	4240,00 €
Montagekosten	5050,00 €
Summe	9290,00 €
Entwicklungskosten	25.650,00 €
Gesamtkosten	34.940,00 €

Merkmale des Systems

- ✓ einfache Bedienung
- ✓ Hohe Arbeitssicherheit
- ✓ Hohe Produktivität (ca. 6 min pro Zyklus)
- ✓ Transferzone bleibt befahrbar / begehbar
- ✓ Geringer Investitionsaufwand
- ✓ Geringe Montagezeit (ca. 60 Arbeitsstunden)
- ✓ Geringer Wartungsaufwand

Gesamtsystem

