



10 9 8 7 **6** 5 4 3 2 1

startIng!

2012

Team: Josephine Cochrane

Gliederung



- Gesamtsystem
- Teilsysteme
- Kostenübersicht
- Fazit

Ausgangssituation Halle



Änderung durch unser System

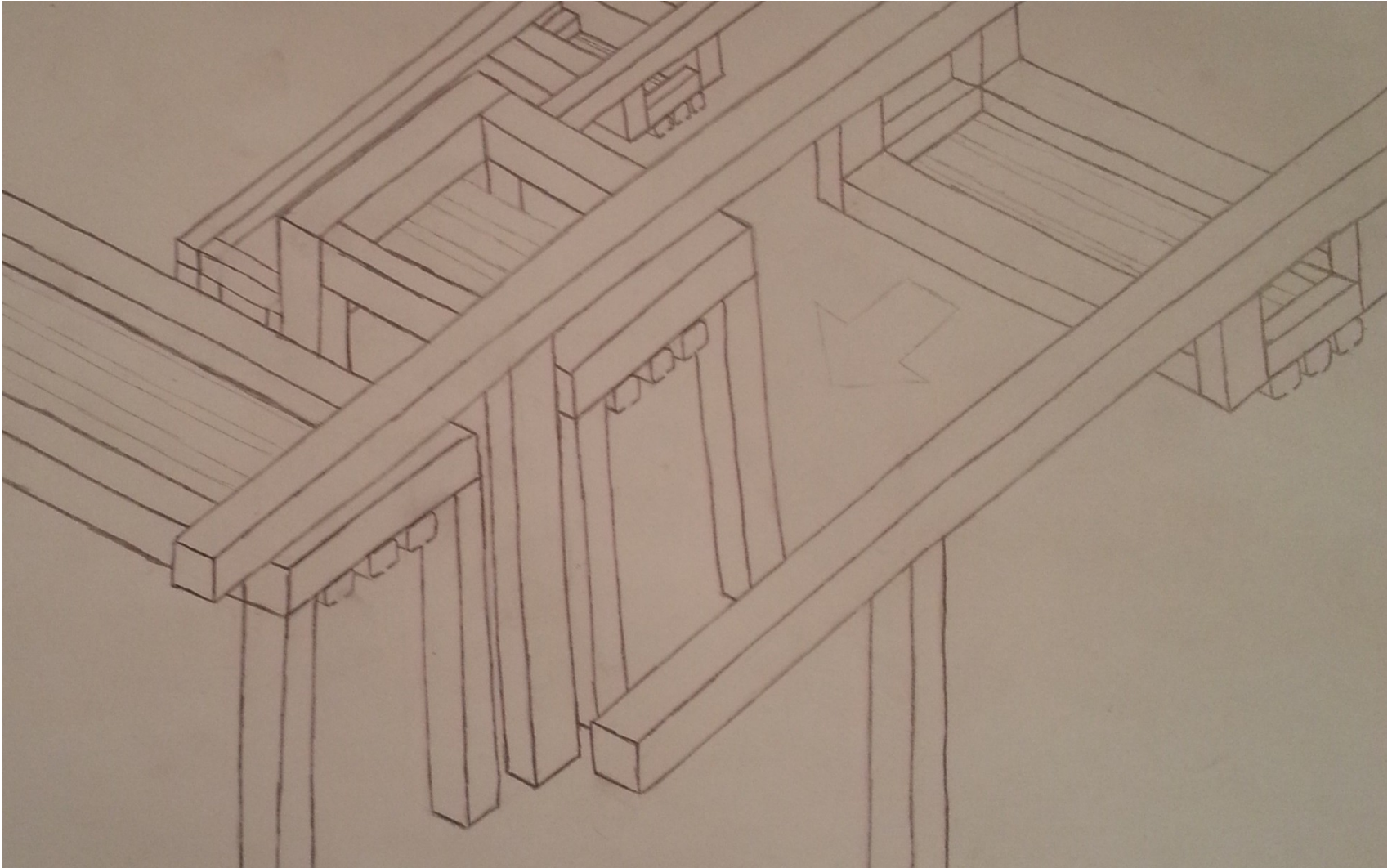

Änderung durch unser System

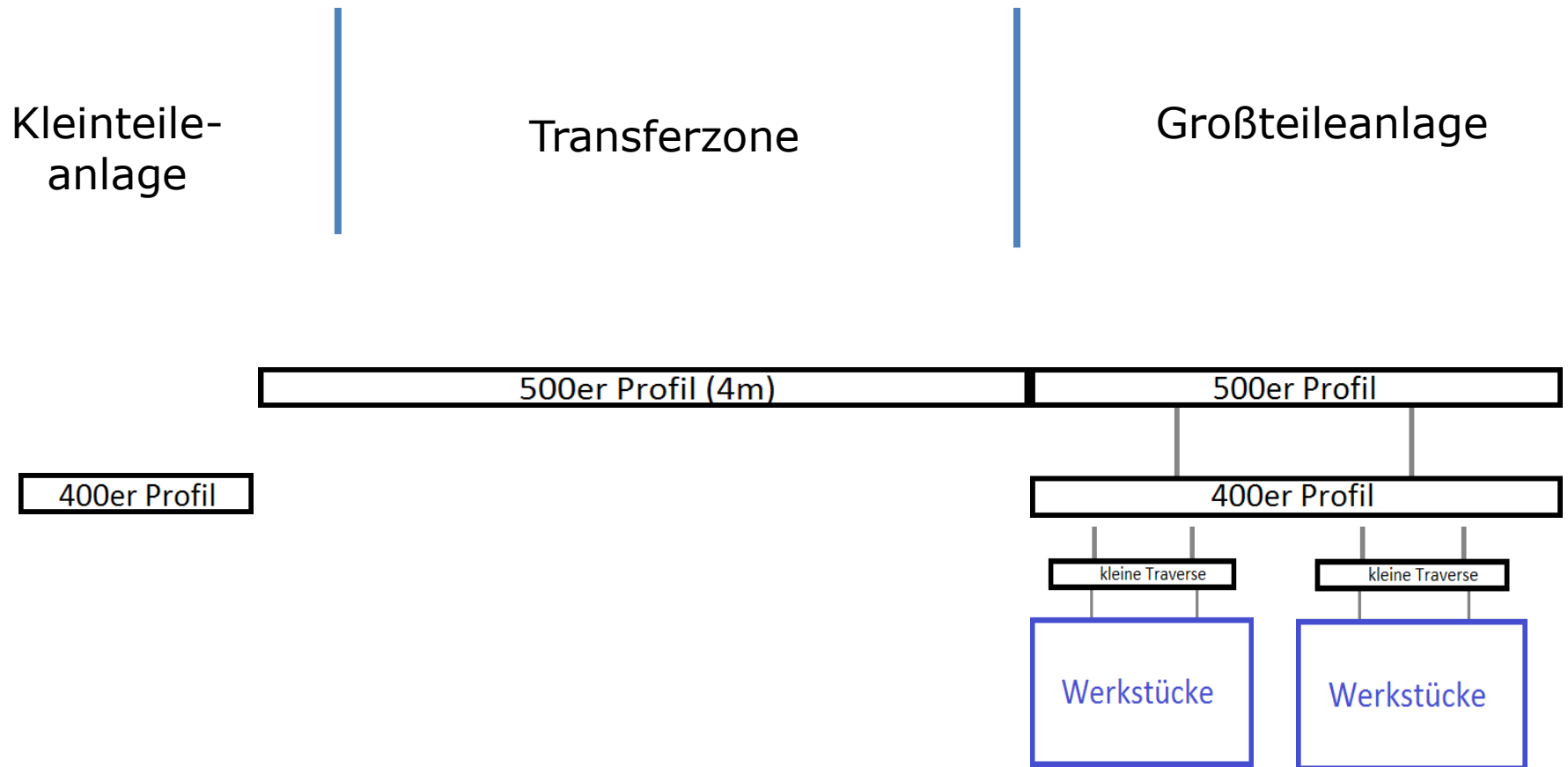

Teilsystem Adapter



- 400er Profil an 500er System
- Bewältigung des Höhen- und Rollenunterschiedes
- Keine neuen Arbeitsschritte

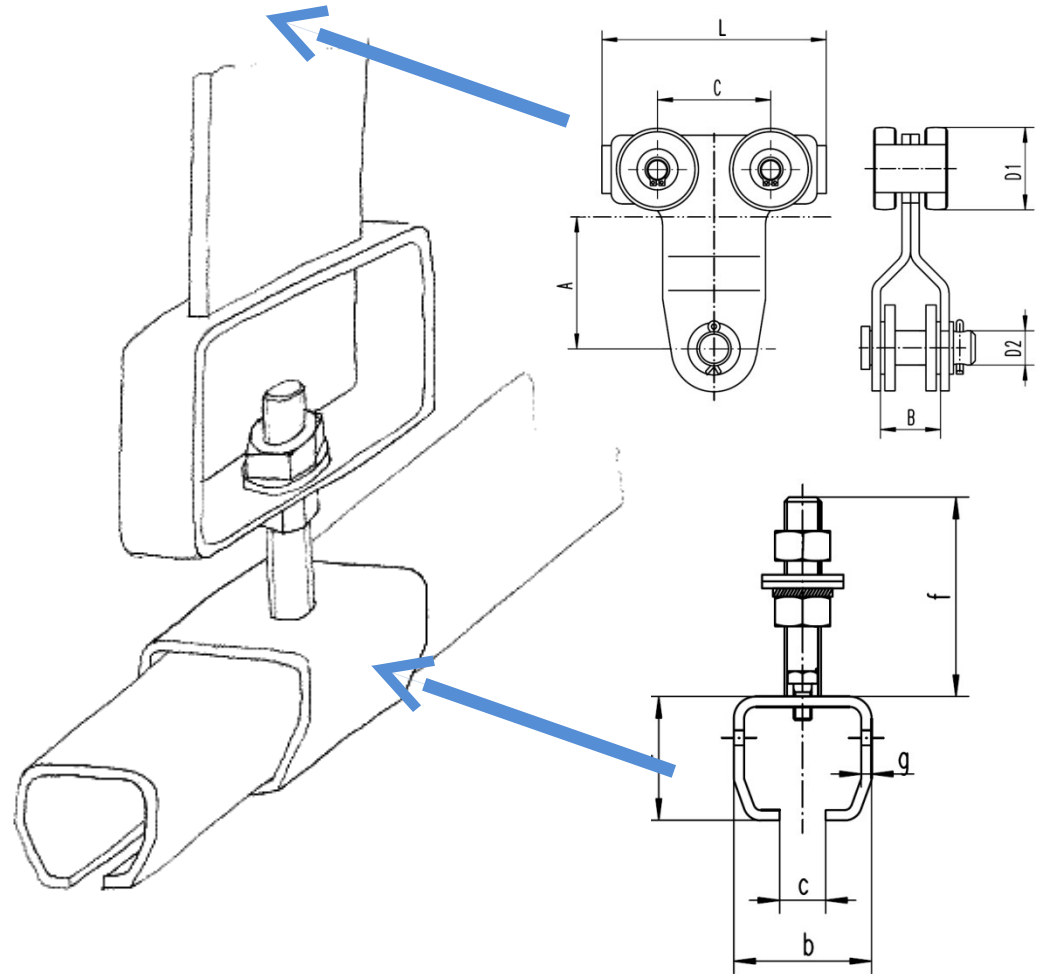

Teilsystem Vorbehandlung

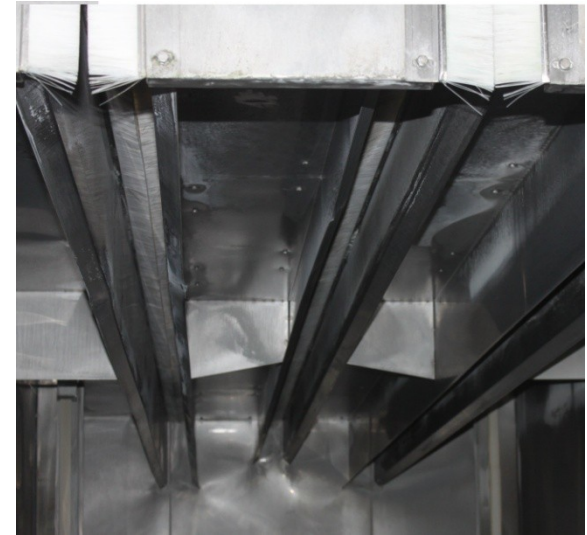
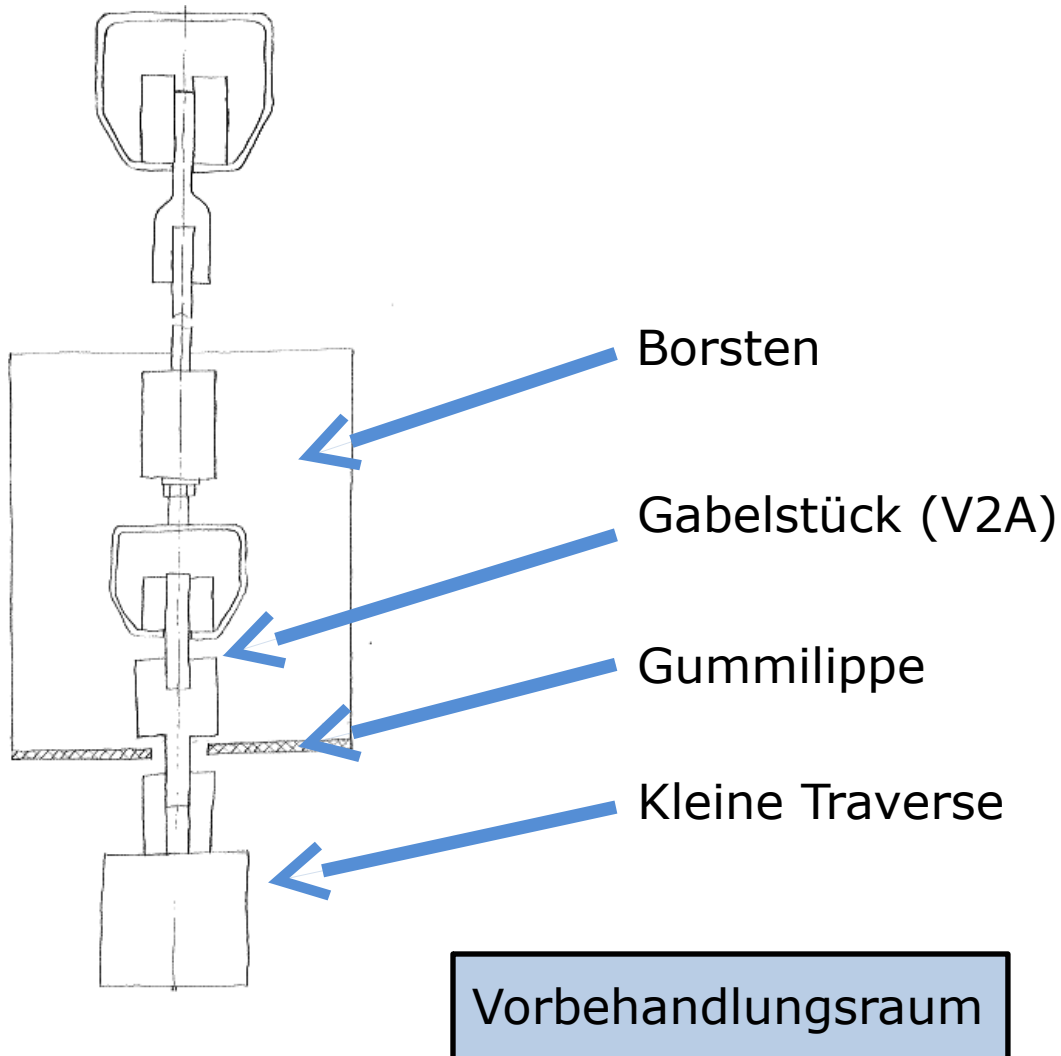

Teilsystem Adapter

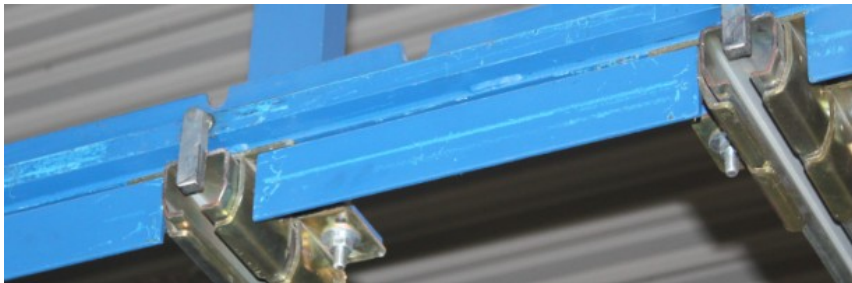

Stoßdämpfer



<http://www.ulbrich.at/industriestosssdaempfer.php>

Kostenübersicht



Art der Kosten	Kosten in €
Anschaffung	5.550,00
Montagekosten	4.800,00
Entwicklungskosten	60.000,00
Wartungskosten	200,00
Laufende Kosten	0,00
<u>Insgesamt:</u>	<u>73.650,00 €</u>

Fazit



Rentierung nach
2,4 Jahren



Einfache
Handhabung



Produktivität wird
Um 850%
gesteigert



Beibehaltung
aller vorhandenen
Systeme

Schlusswort



„Es sind immer die einfachsten Ideen, die außergewöhnliche Erfolge haben.“

Von Leo N. Tolstoi

