

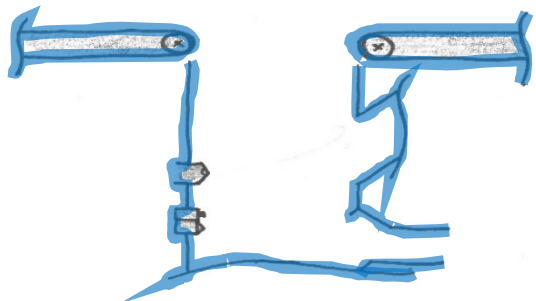

# RECYCLING VON PET-FLASCHEN

**LOST LABELS ENGINEERING**

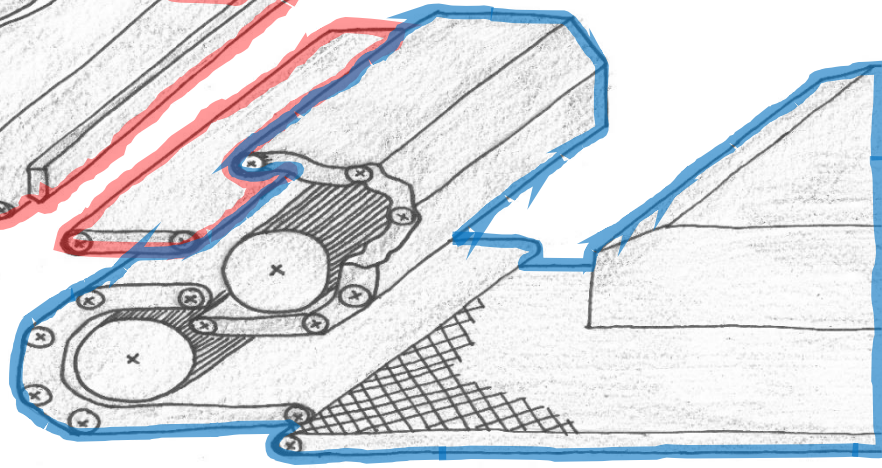

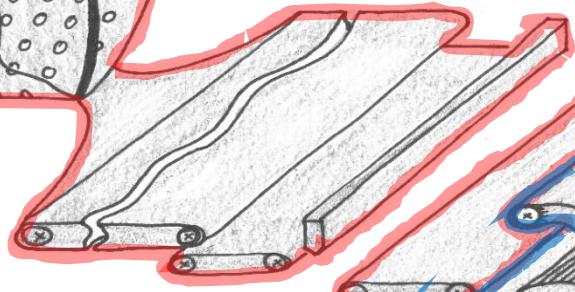
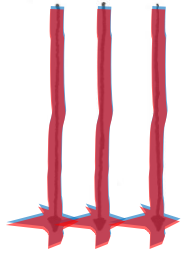
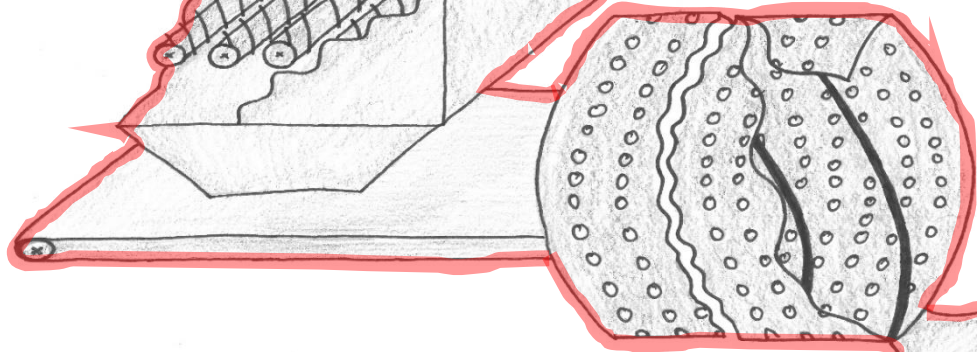
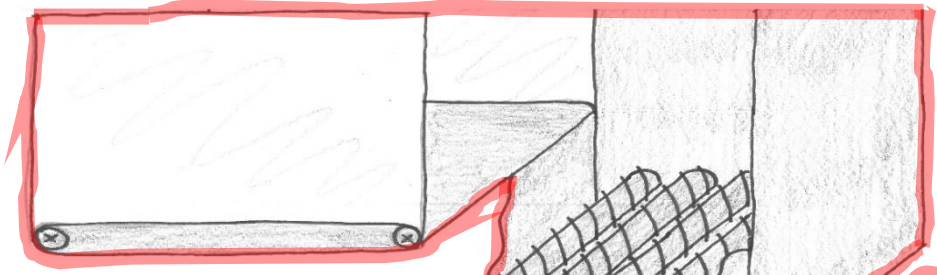
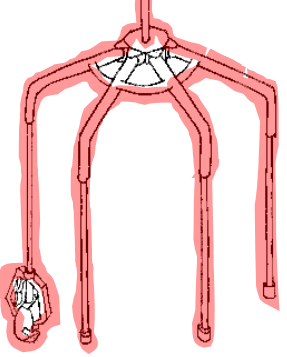

## POS. 1 KRANSYSTEM

- HALBAUTOMATISCHES VERFAHREN

## POS. 2 HYDRAULIK-KLEMM-SCHNEIDER

- DURCHTRENNEN UND FESTHALTEN DER DRÄHTE

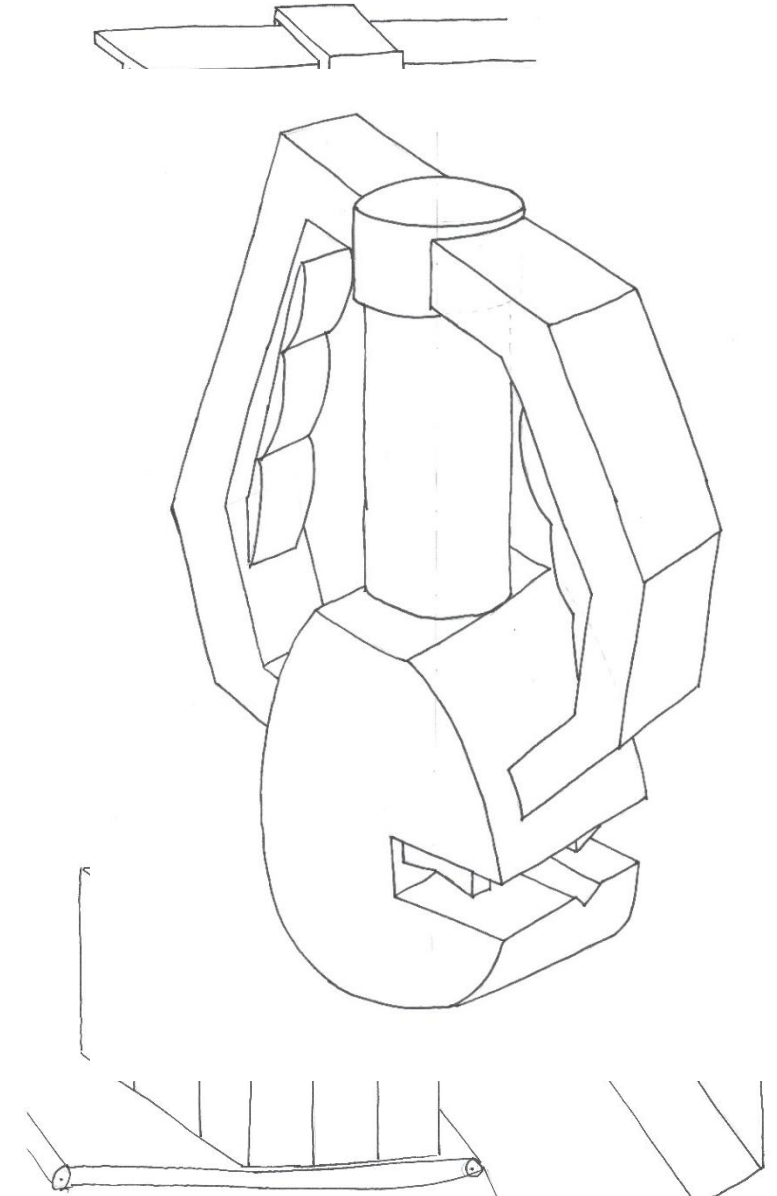
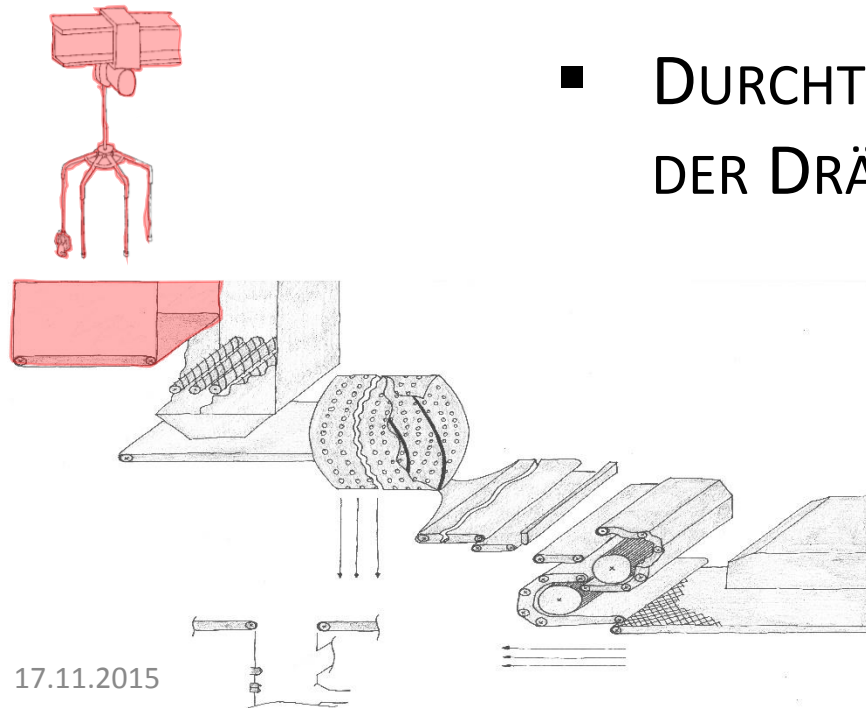

## Pos. 3 MISCHGUTLÖSER

- BRECHEN DES BALLENS DURCH FALL
- GROBE ZERKLEINERUNG

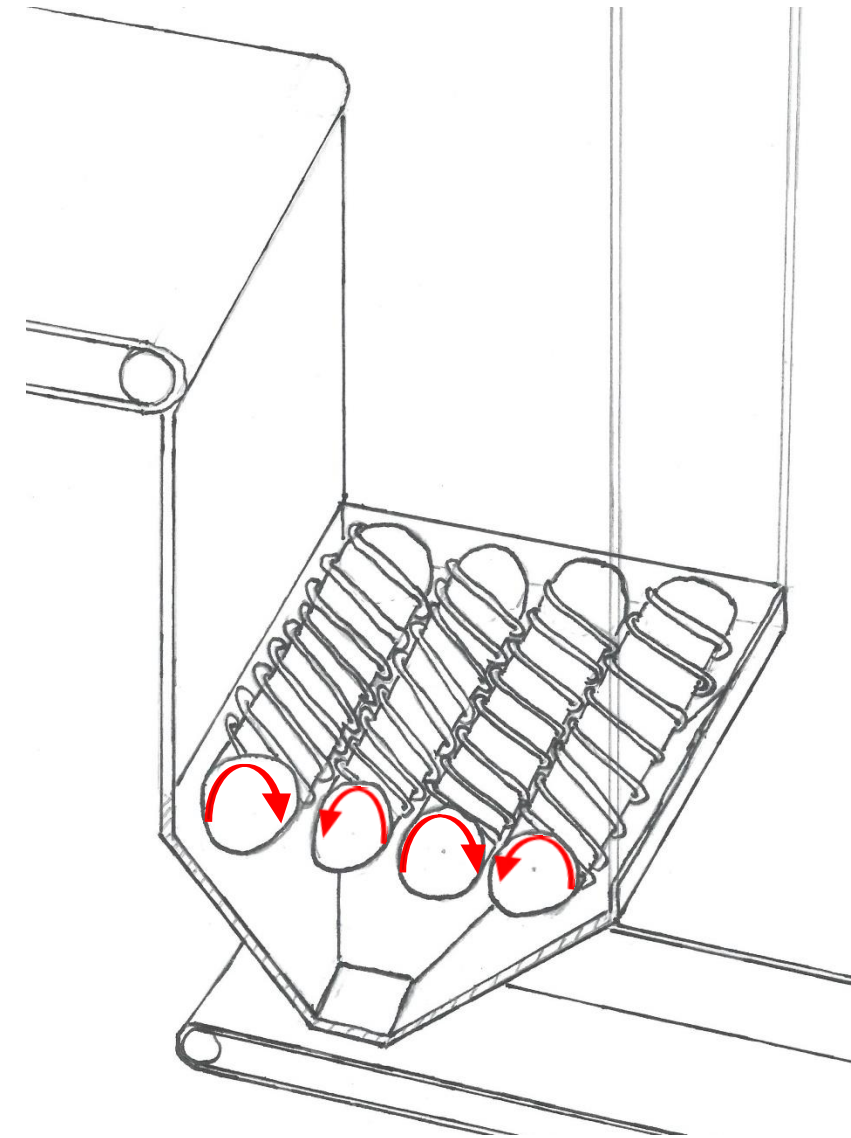
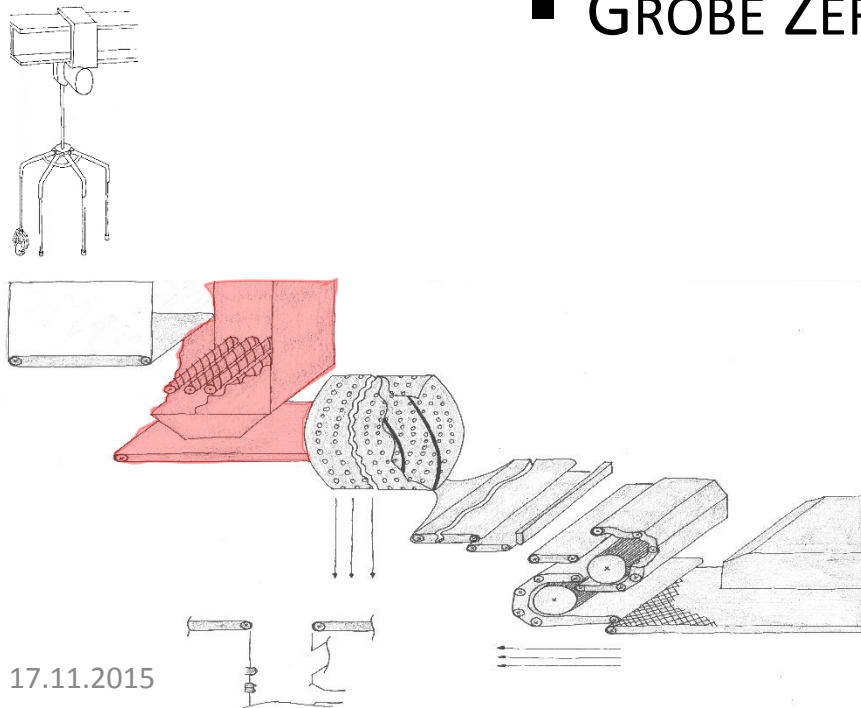

## Pos. 4 DURCHLAUFTROMMEL

- AUSSCHIEDUNG VON KLEINTEILEN
- ANSCHLIEßEND VERTEILUNG GELÖSTER FLASCHEN PER RÜTTELBAND

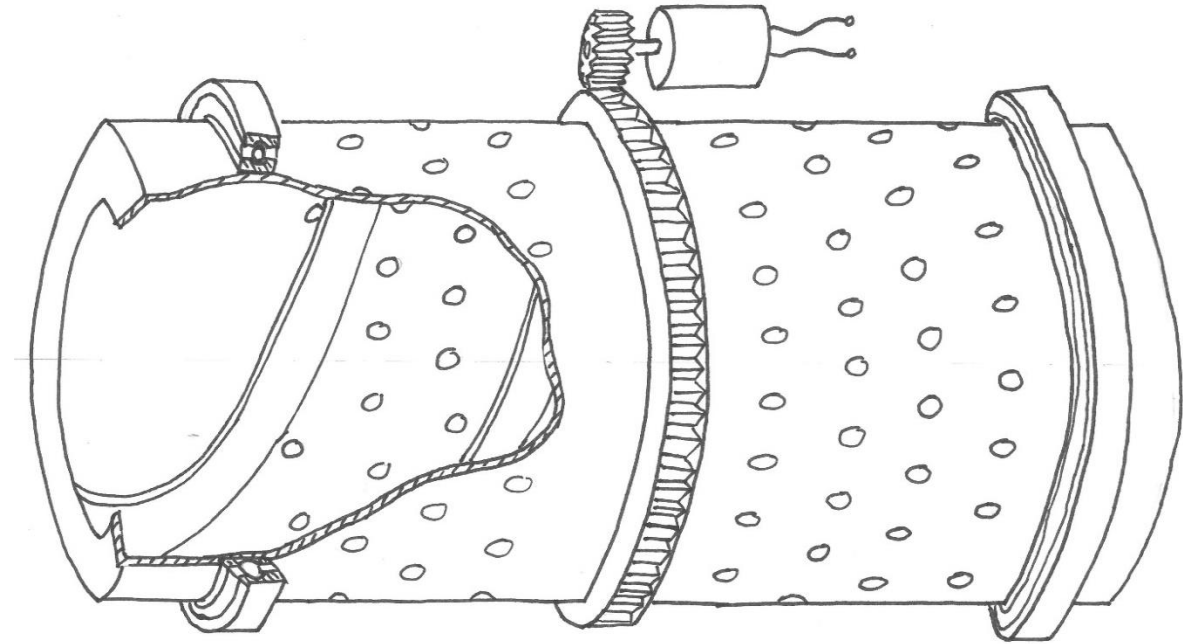
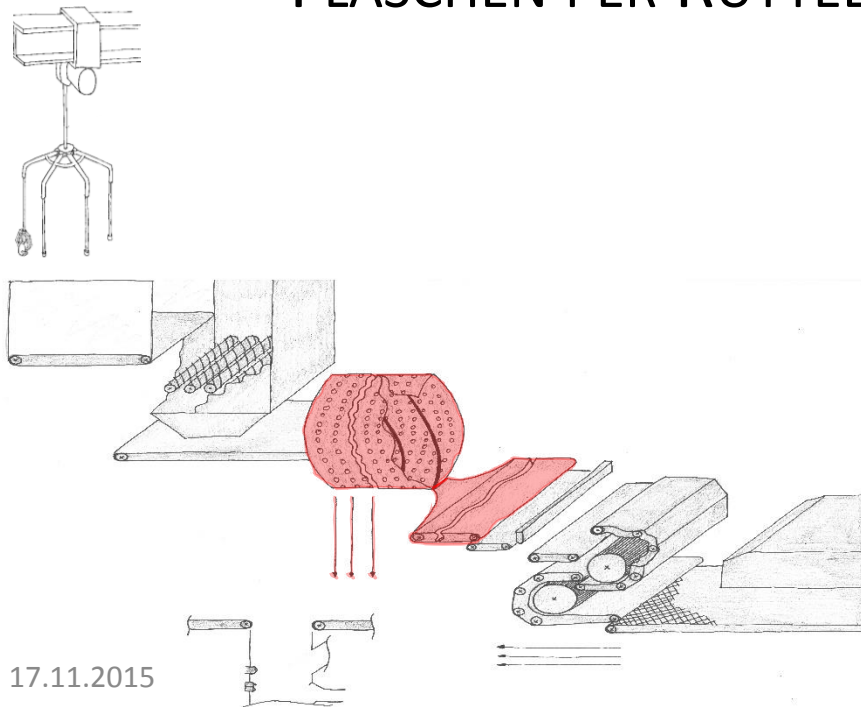

# Pos. 5 METALLABSCHIEDER

- INDUKTIVER NÄHERUNGSSENSOR

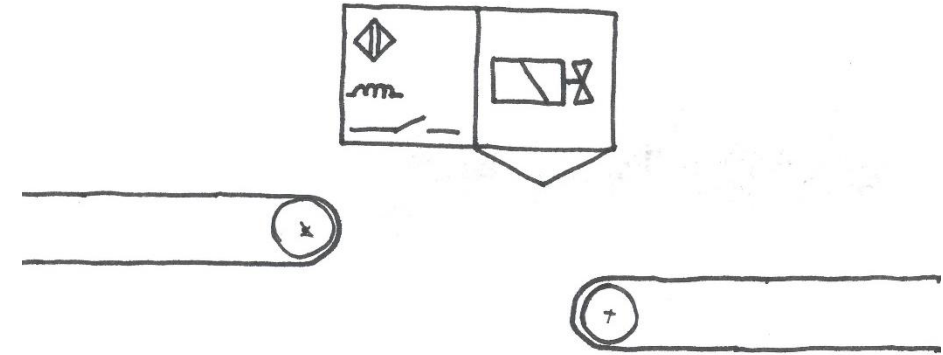
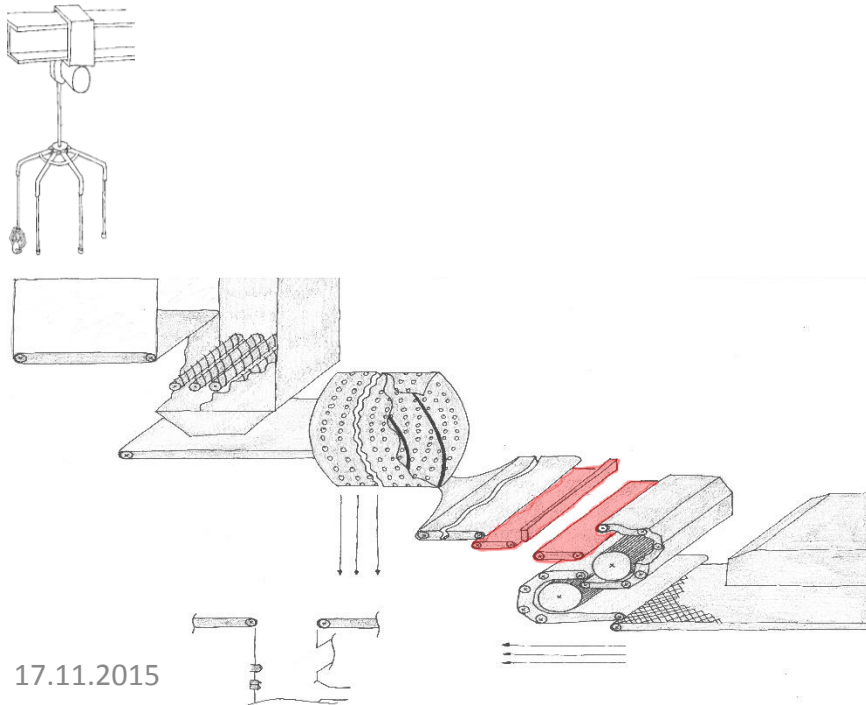

# Pos. 6 BÜRSTENSYSTEM

## ■ FÜHRUNGSSCHIENE

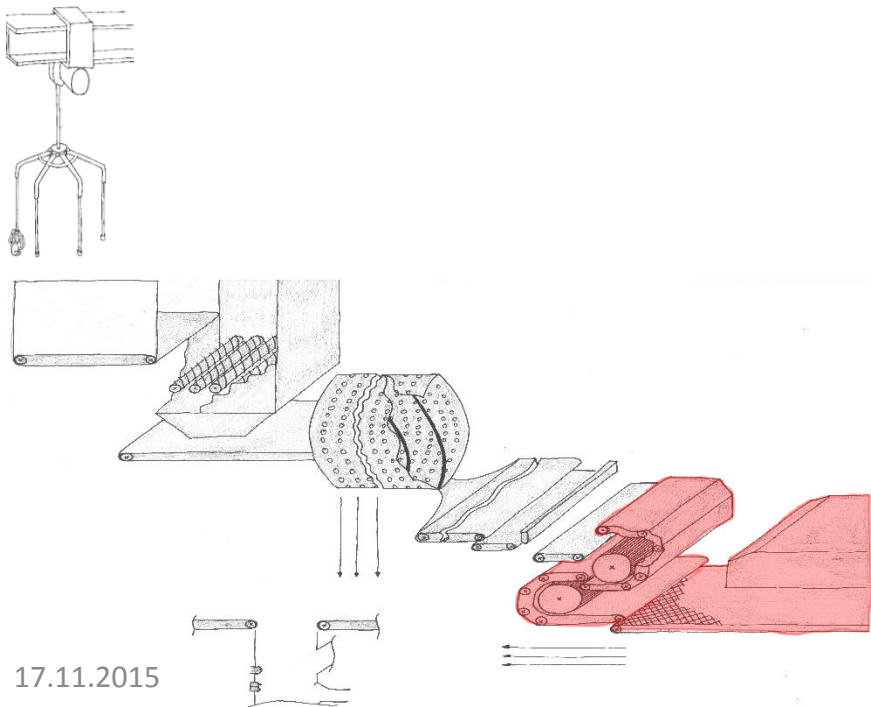

17.11.2015

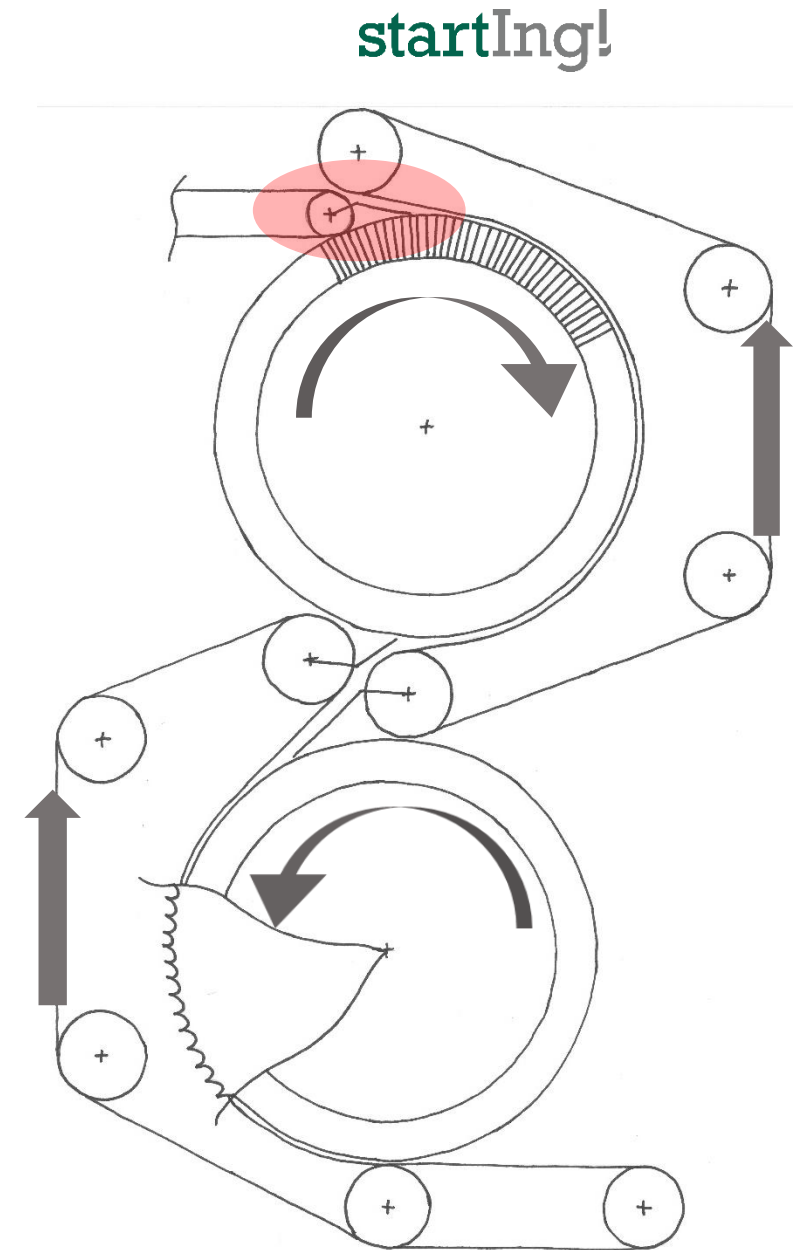

TEAM ADA LOVELACE



# Pos. 6.1 FÜHRUNGSSCHIENE

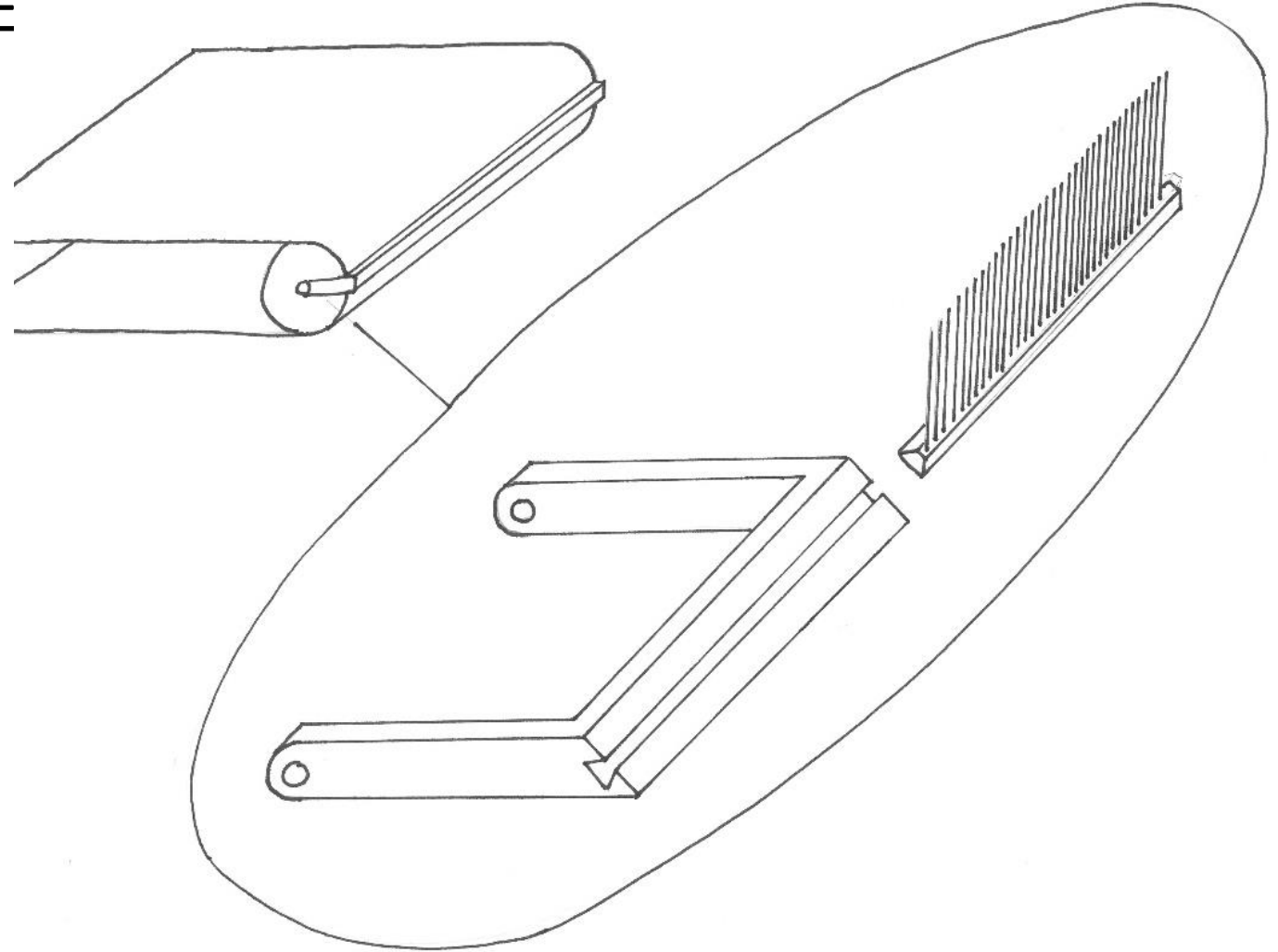
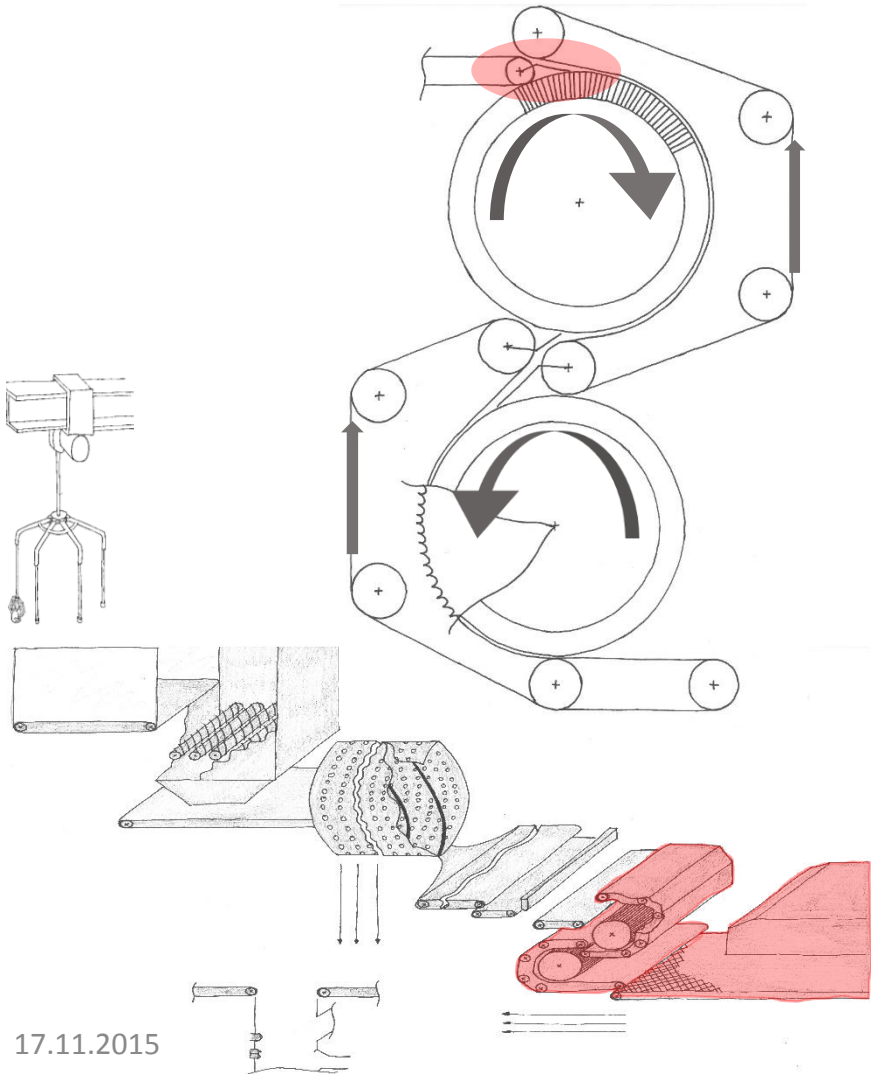



# Pos. 6 BÜRSTENSYSTEM

- FÜHRUNGSSCHIENE
- FLIEßBAND

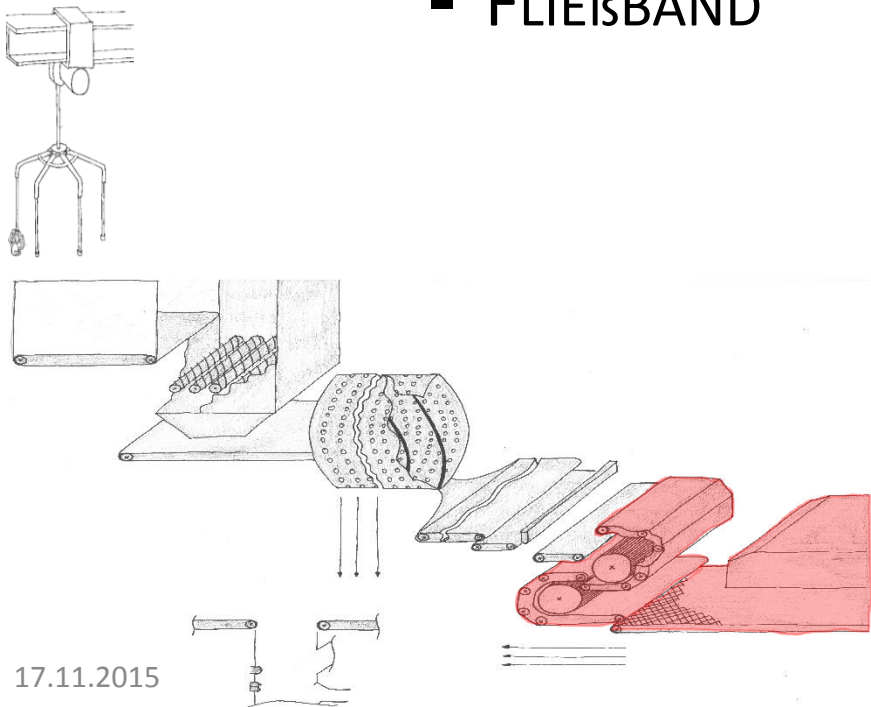

17.11.2015

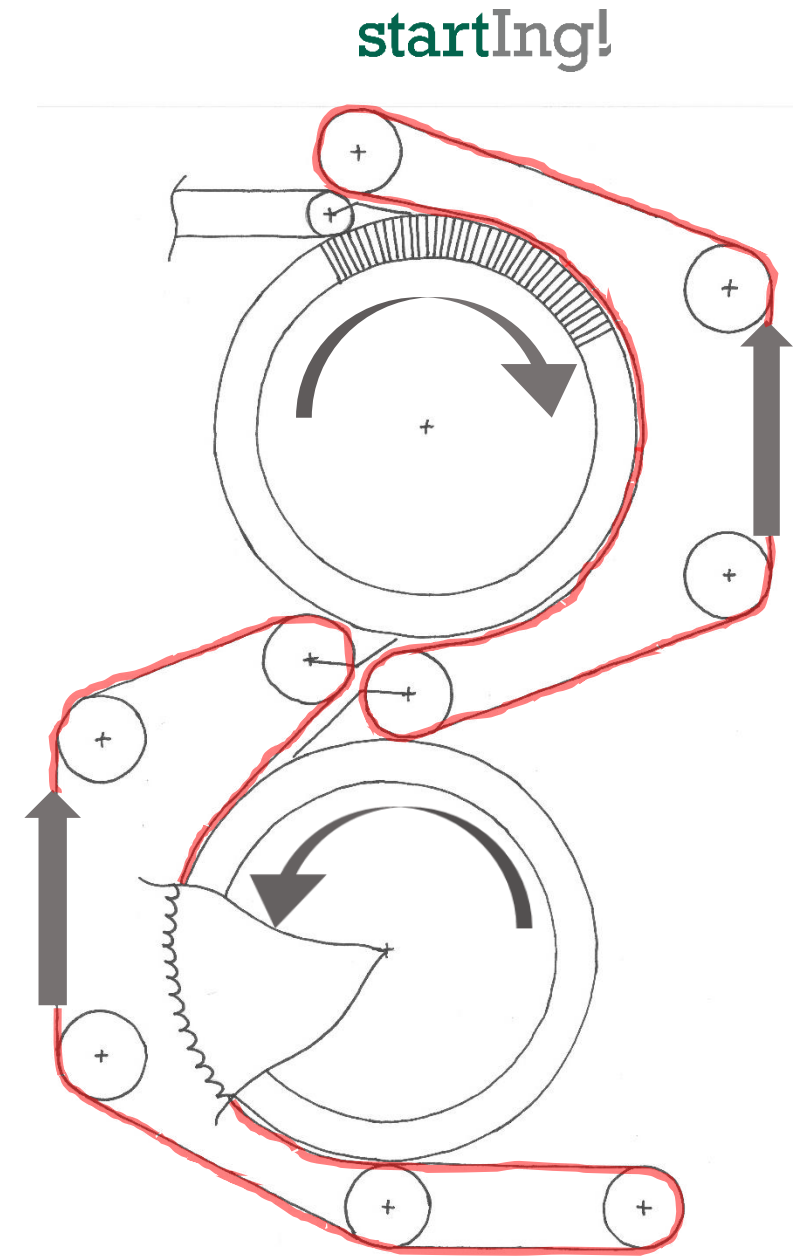

startIng!

# Pos. 6.2 FLIEßBAND

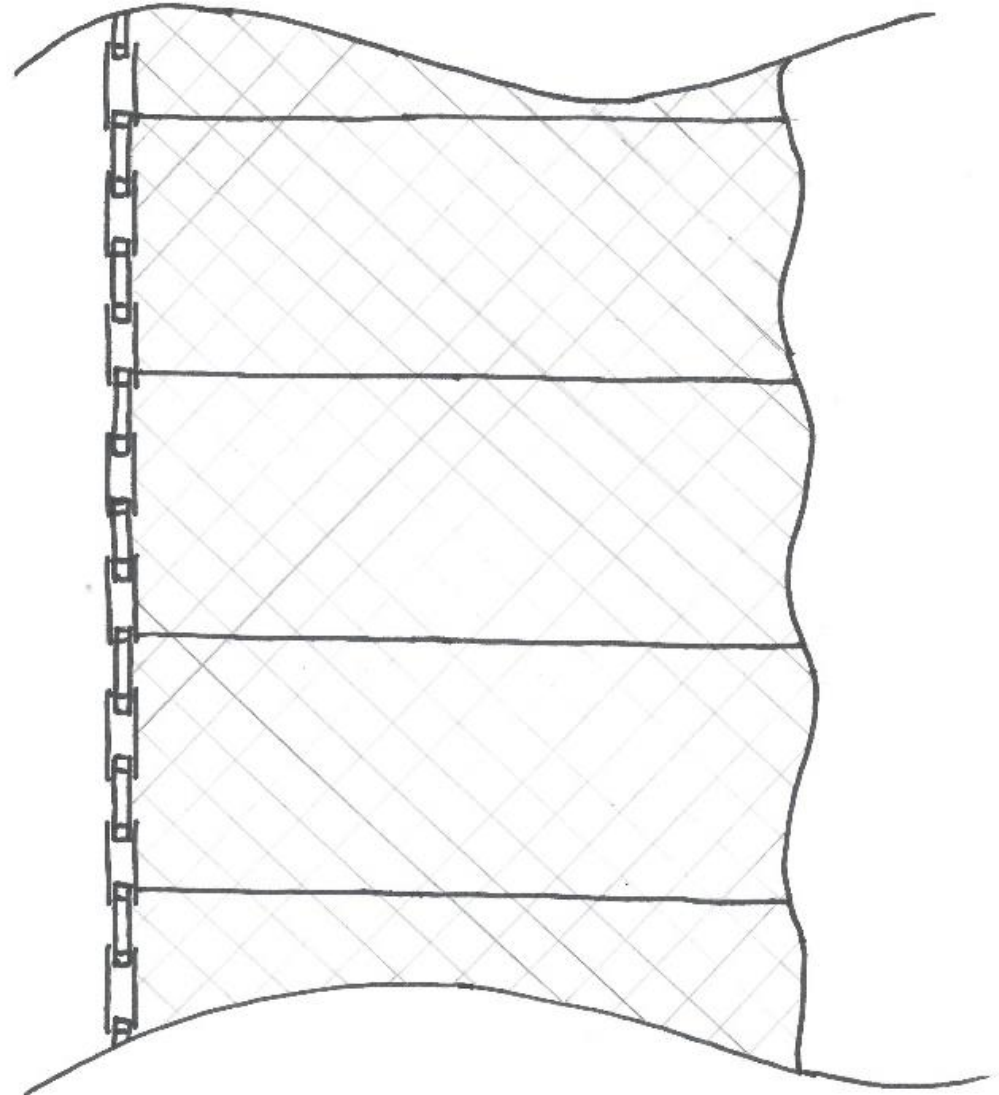
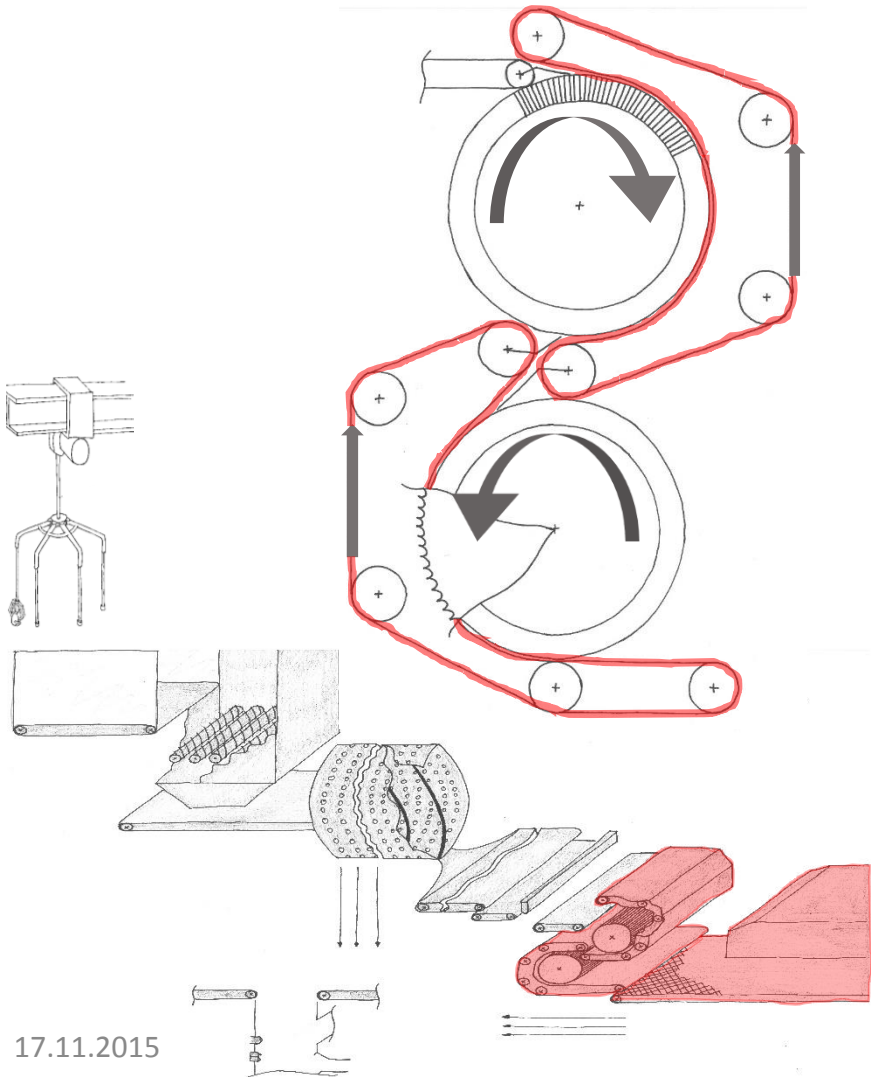

# Pos. 6 BÜRSTENSYSTEM

- FÜHRUNGSSCHIENE
- FLIEßBAND
- BÜRSTENROLLEN

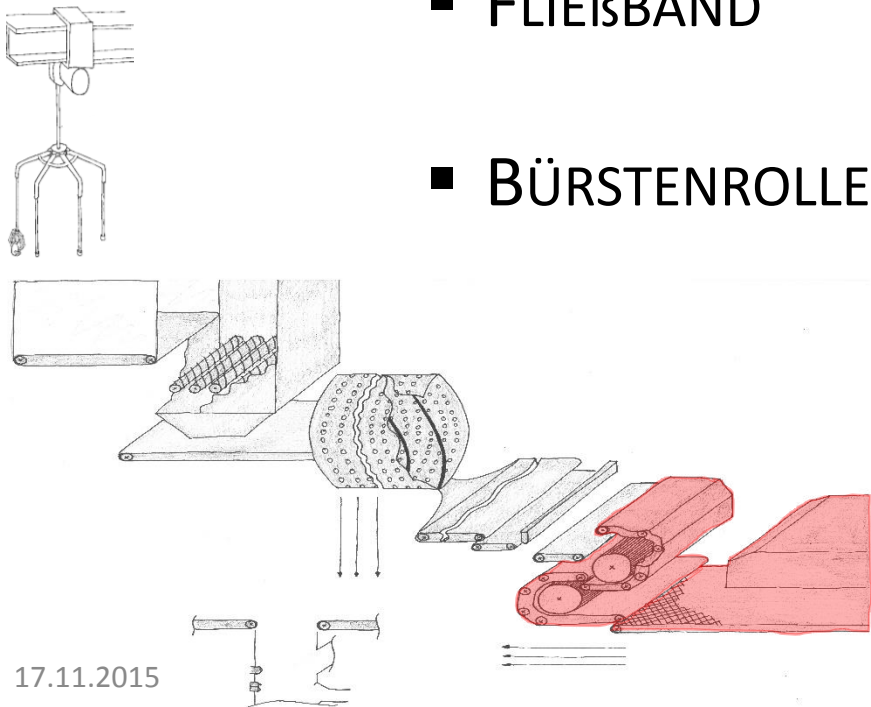

startIng!

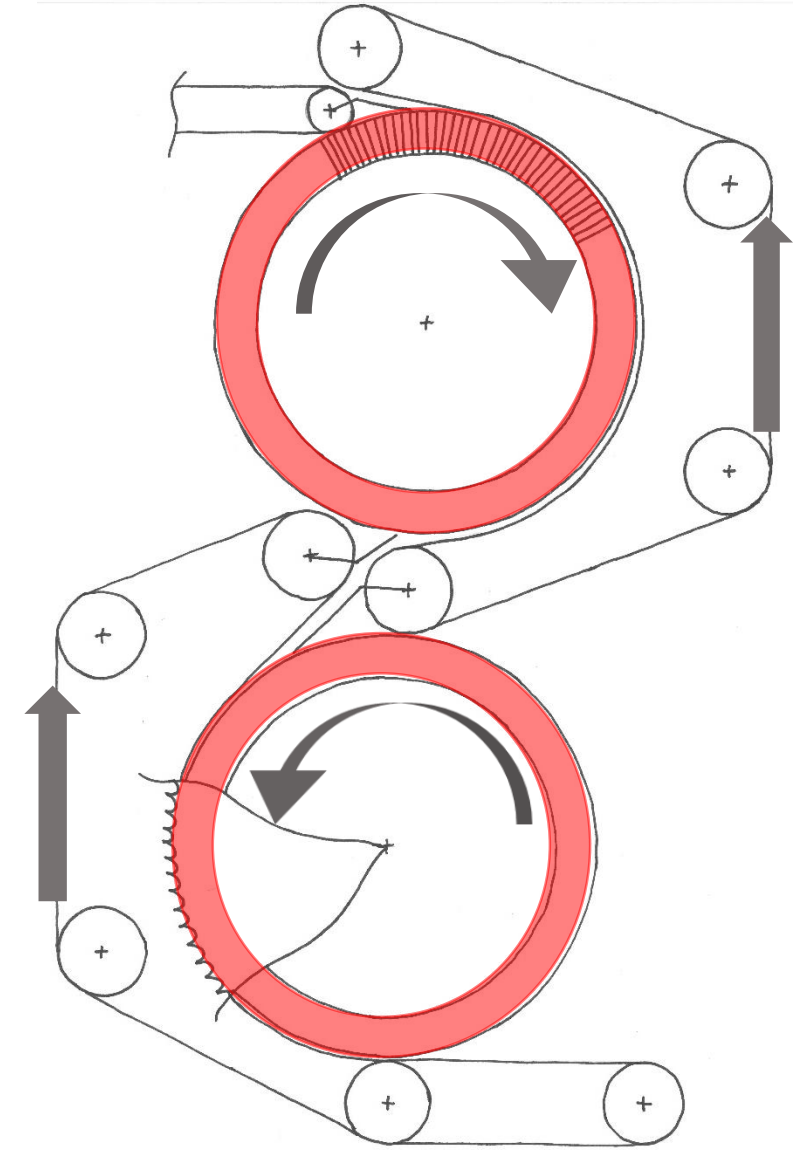

# Pos. 6.3 BÜRSTENROLLEN

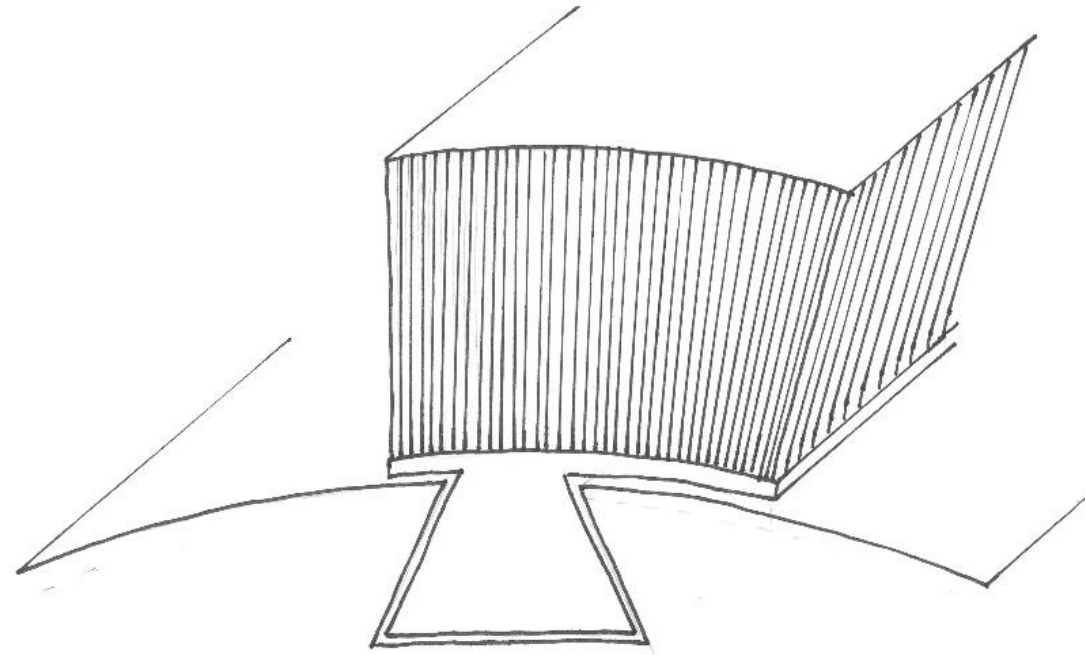
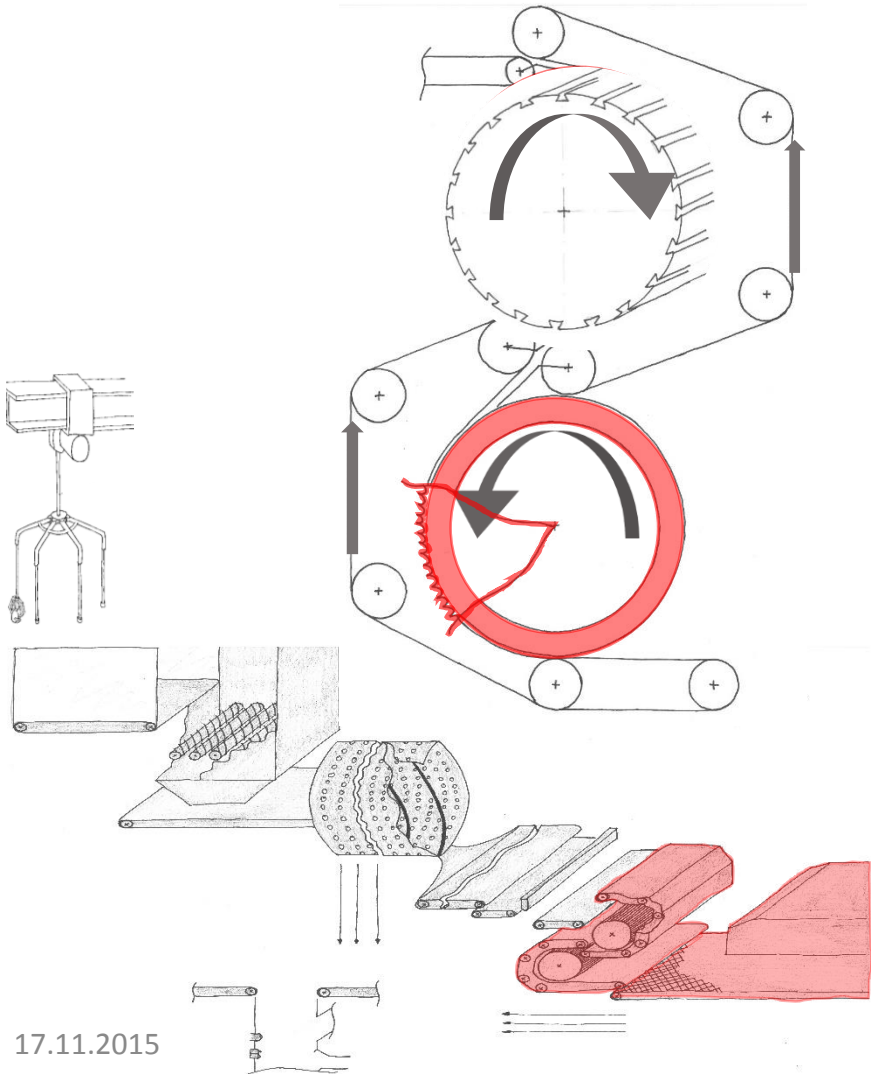



# Pos. 6 BÜRSTENSYSTEM

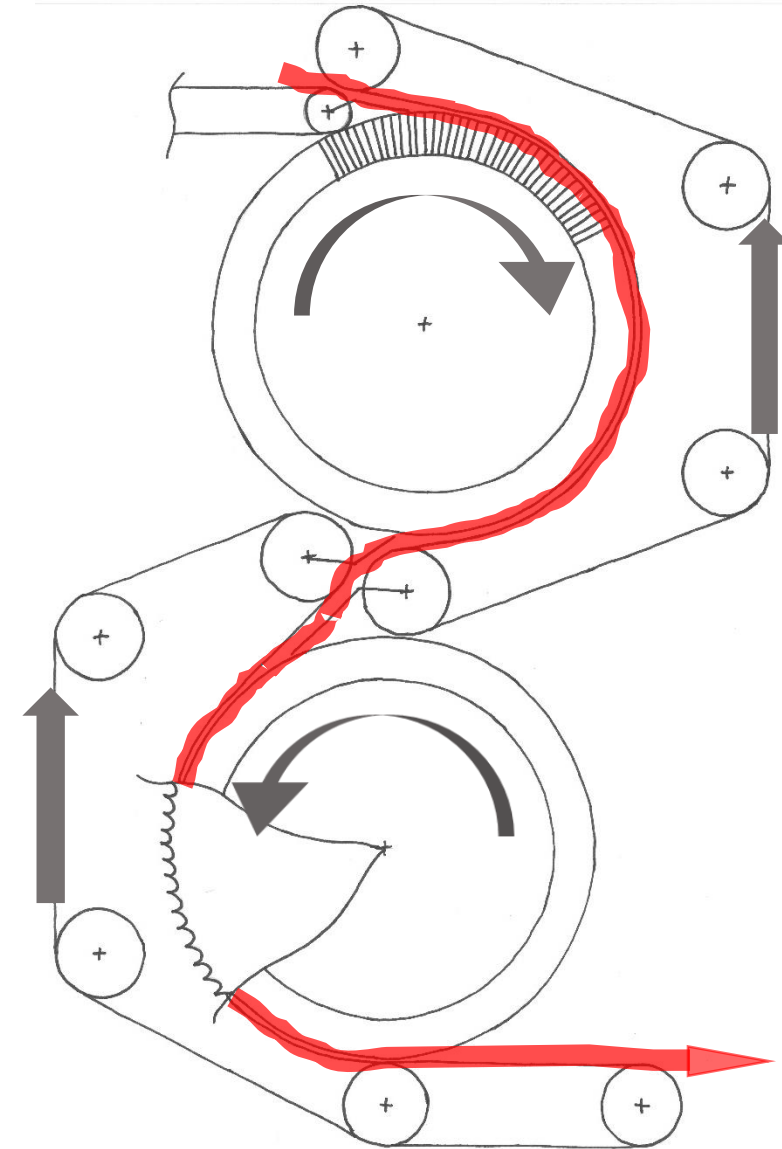
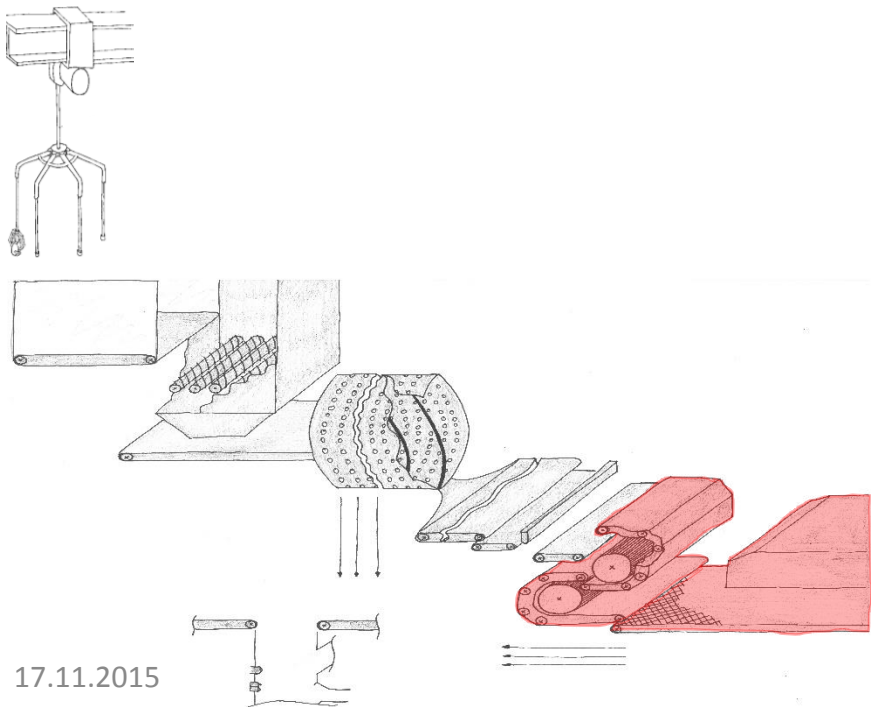

# Pos. 7 GITTERFLIEßBAND

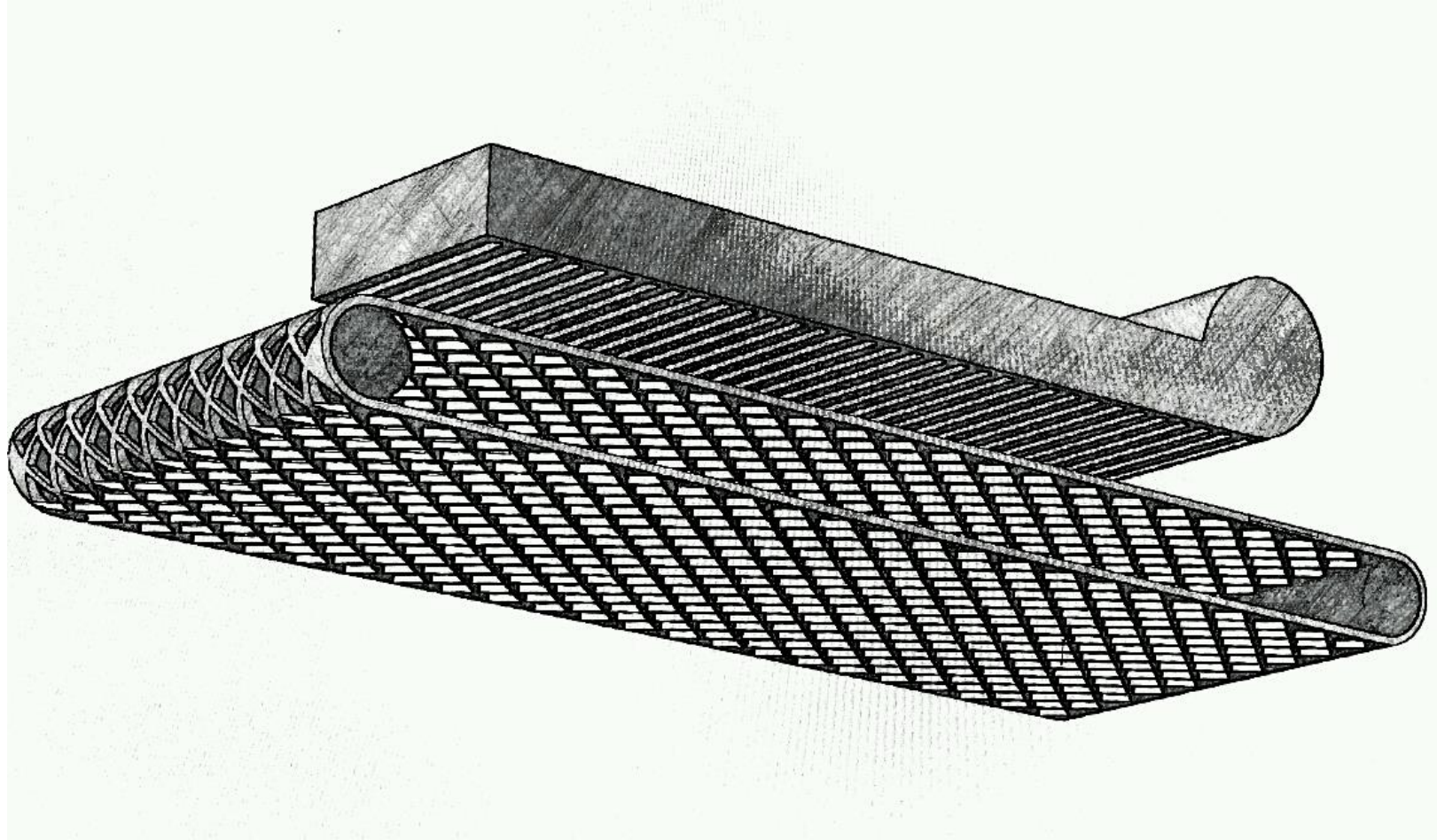
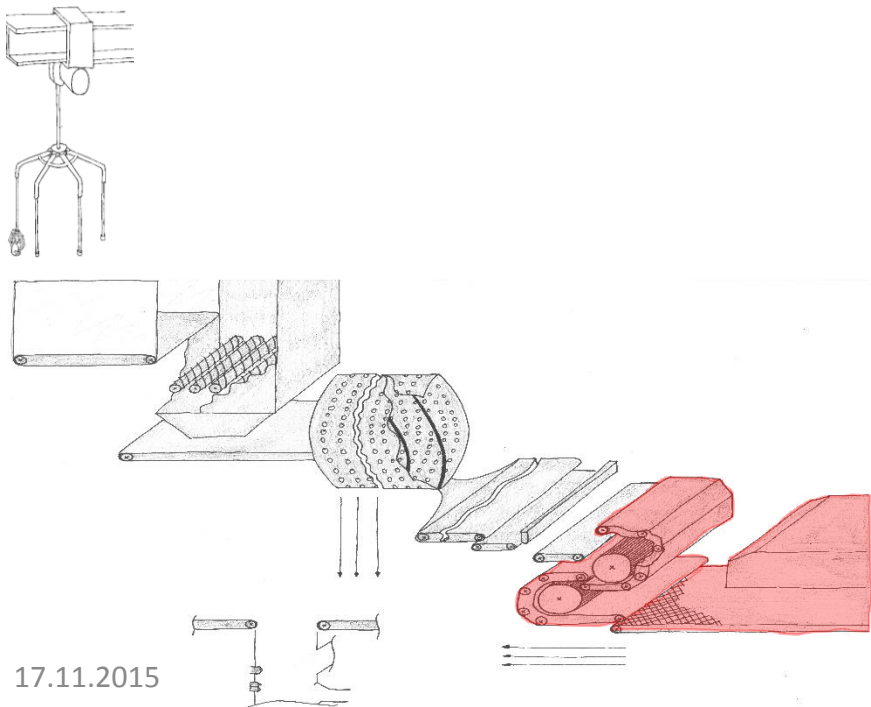

## Pos. 8 LUFTABSCHIEDER

- TRENNEN DES AUSSCHUSSES
- KONTINUIERLICHER LUFTSTROM

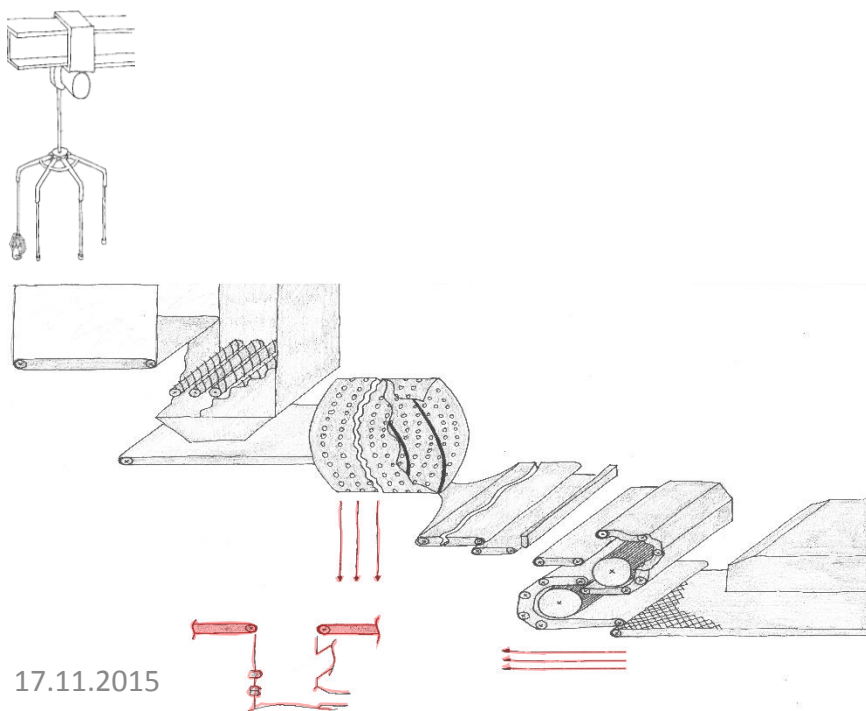

METALL (AUS TROMMEL)  
PET-KLEINTEILE  
ETIKETTEN

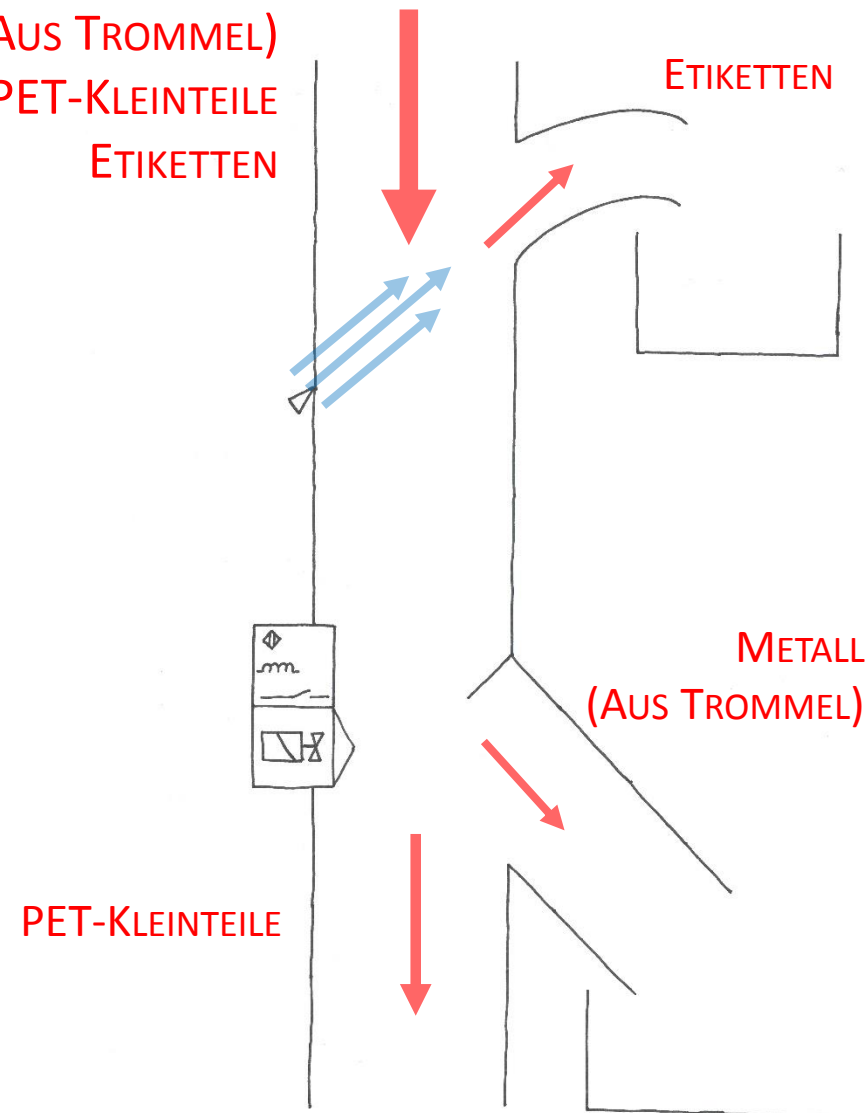

## WIRTSCHAFTLICHKEIT

■ MATERIALKOSTEN	250.000 €
■ PERSONALKOSTEN	700.000 €
■ ENTWICKLUNGSKOSTEN	<u>800.000 €</u>
	1.750.000 €



## ZUSAMMENFASSUNG

- KOMPLETTE ENTFERNUNG DER ETIKETTEN
- KAUM VERSCHLEIßTEILE
  - EXTREM KURZE WECHSELDAUER (STECKSYSTEM)
- TROCKENES SYSTEM (KEINE AUFBEREITUNG VON FLÜSSIGKEITEN NOTWENDIG)
- ENERGETISCHE EFFIZIENZ