

Stromabnehmer für Hybrid- Mittelführerhaus-Lok

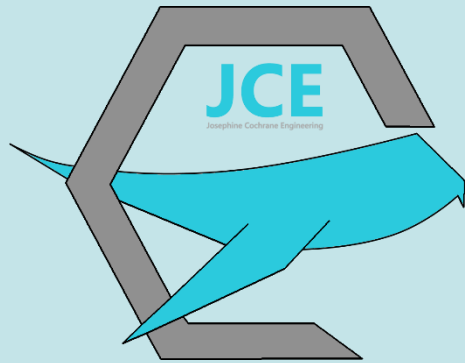

Team Josephine Cochrane©

Dennis Bruhn, Mohammed El Cheikh, Joshua Engels,
Mina Fatah, Muhammed Amin Hag, Dominic Hold,
Daniel Horst, Rike Schröder, Lara-Marie Völmicke

Unserere Idee



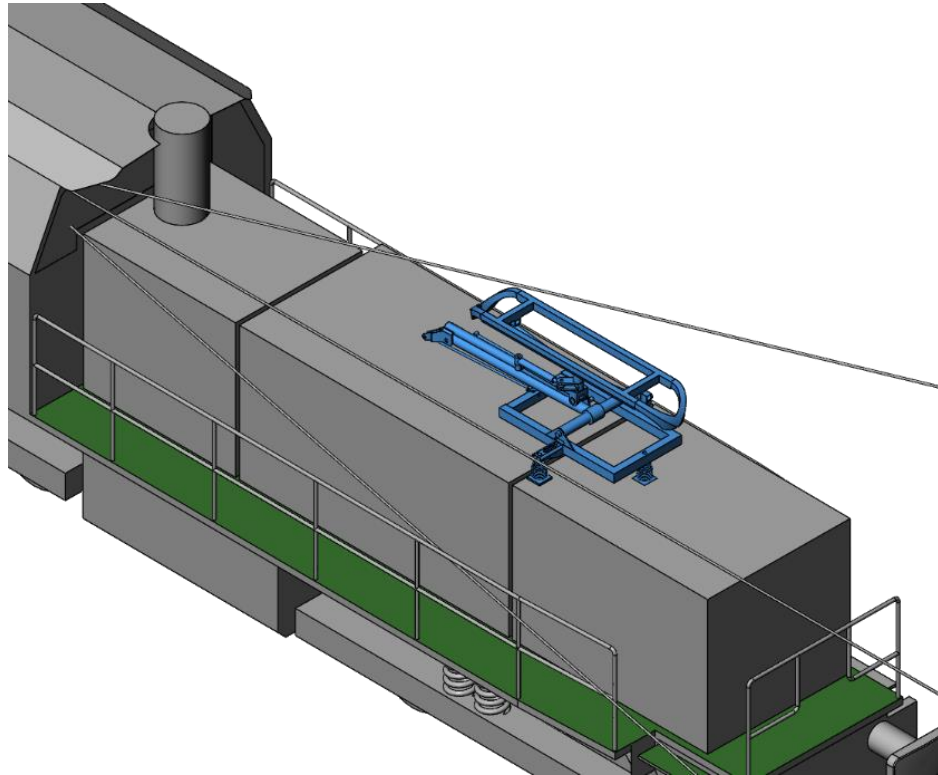

Eingefahrener Zustand

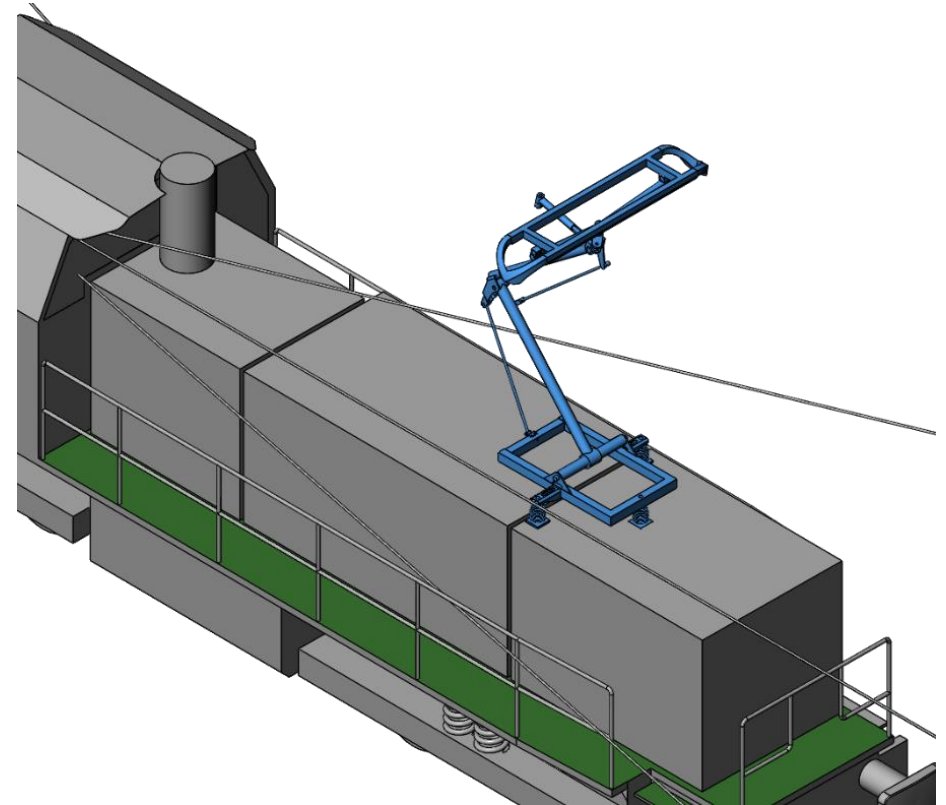

Ausgefahrener Zustand

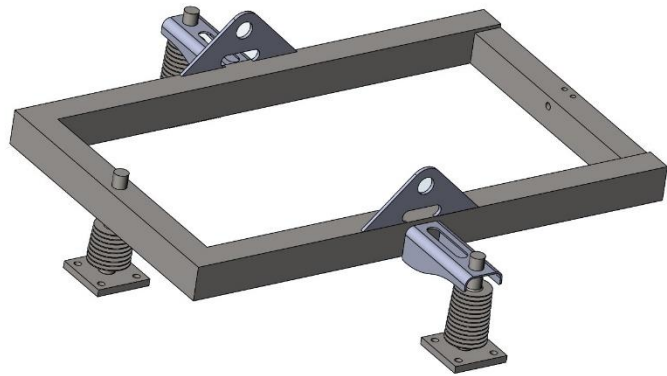

Befestigung



Hebearm



Drehkopf

Einnahmen	
Preis pro Stück	10.750€
UMSATZ BEI 500 STÜCK	5.375.000€

Ausgaben	
Entwicklungskosten	66.000€
Materialkosten (für 500 Stück)	1.856.000€
Lohnkosten/Jahr	1.050.000€
PRODUKTIONSKOSTEN	2.972.000

Gewinn	
UMSATZ MINUS PRODUKTIONSKOSTEN	2.403.000€



■ Gewinn ■ Produktionskosten

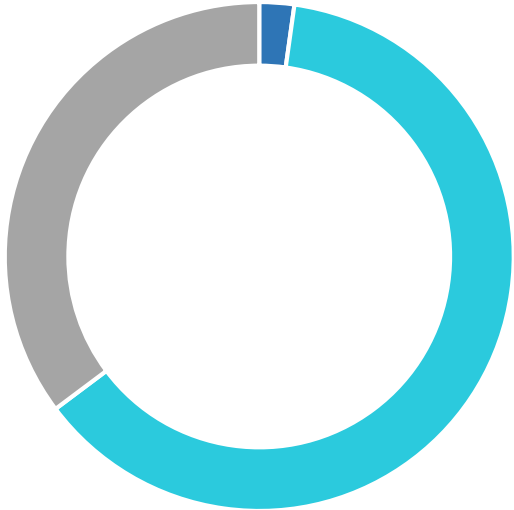

■ Entwicklungskosten ■ Materialkosten ■ Lohnkosten/Jahr

Man muss das Rad nicht
neu erfinden, sondern
lediglich optimieren.

